

Operator's Manual

optris® PI

400i/ 450i/ 450i G7/ 640i/ 640i G7/ 05M/ 08M/ 1M



Infrared camera

Optris GmbH

Ferdinand-Buisson-Str. 14
13127 Berlin
Germany

Tel.: +49 30 500 197-0

Fax: +49 30 500 197-10

E-mail: info@optris.global

Internet: www.optris.global



Table of contents

Table of contents	3
1 General Notes	7
1.1 Intended use	7
1.2 Warranty	9
1.3 Scope of delivery	10
1.4 Maintenance	10
1.4.1 Cleaning.....	10
1.5 Model overview.....	11
2 Technical Data	12
2.1 General specifications	12
2.2 Electrical specifications.....	16

2.3	Measurement specifications	17
2.4	Optical specifications	21
3	Mechanical Installation	28
3.1	Dimensions	30
3.2	Changing the lens.....	37
3.3	Fixing the focus of the lens (only for PI 05M/ 08M/ 1M)	38
3.4	Mounting accessories (optional)	40
3.5	High temperature accessories	41
3.5.1	CoolingJacket Advanced	41
3.5.2	Laminar air purge for CoolingJacket.....	45
3.5.3	Outdoor protective housing.....	46
4	Electrical Installation.....	47
4.1	Process interface	48

4.1.1	PIN allocation.....	50
4.1.2	Industrial Process Interface (optional).....	52
4.2	Example for a Fail-Safe monitoring of the PI with a PLC	55
4.3	USB cable extension	56
5	IRmobile App.....	58
6	Software PIX Connect	60
6.1	Installation and initial start-up	61
6.2	Software window.....	63
6.2.1	Basis features of the software PIX Connect	64
7	Basics of Infrared Thermometry	68
8	Emissivity	74
8.1	Definition	74
8.2	Determination of unknown emissivity	76

8.3	Characteristic emissivity	78
Appendix A	– Table of emissivity for metals	79
Appendix B	– Table of emissivity for non-metals	81
Appendix C	– Quick start for serial communication	82
Appendix D	– Interprocess Communication (IPC)	84
Appendix E	– PIX Connect Resource Translator	85
Appendix F	– Wiring diagrams PIF	86
Appendix G	– Declaration of Conformity	90

1 General Notes

1.1 Intended use

Thank you for choosing the **optris® PI** infrared camera.

The optris PI calculates the surface temperature based on the emitted infrared energy of objects [**► 7 Basics of Infrared Thermometry**]. The two-dimensional detector (FPA - focal plane array) allows a measurement of an area and will be shown as thermal image using standardized palettes. The radiometric processing of the picture data enables the user to do a comfortable detailed analysis with the software PIX Connect.

The PI is a precise instrument and contains an extremely sensitive infrared detector and a high-quality lens.



The alignment of the camera to **intensive energy sources** (e.g. devices which emit laser radiation or reflections of such equipment) can cause an **irreparable defect of the infrared detector**. This is also valid if the camera is switched off.

Such kinds of damages are excluded from warranty.



Read the manual carefully before the initial start-up. The producer reserves the right to change the herein described specifications in case of technical advance of the product.



- Avoid abrupt changes of the ambient temperature.
- Avoid static electricity, arc welders, and induction heaters. Keep away from very strong EMF (electromagnetic fields).
- In case of problems or questions which may arise when you use the infrared camera, please contact our service department.



► All accessories can be ordered according to the referred part numbers in brackets [].

1.2 Warranty

Each single product passes through a quality process. Nevertheless, if failures occur contact the customer service at once. The warranty period covers 24 months starting on the delivery date. After the warranty is expired the manufacturer guarantees additional 6 months warranty for all repaired or substituted product components. Warranty does not apply to damages, which result from misuse or neglect. The warranty also expires if you open the product. The manufacturer is not liable for consequential damage or in case of a non-intended use of the product.

If a failure occurs during the warranty period the product will be replaced, calibrated or repaired without further charges. The freight costs will be paid by the sender. The manufacturer reserves the right to exchange components of the product instead of repairing it. If the failure results from misuse or neglect the user has to pay for the repair. In that case you may ask for a cost estimate beforehand.

1.3 Scope of delivery

- PI 400i, PI 450i, PI 450i G7, PI 640i, PI 640i G7, PI 05M, PI 08M or PI 1M incl. 1 lens
- USB-cable: 1 m (standard scope of supply, no IP67 protection class)
1 m, 3 m, 5 m, 10 m, 20 m (optional, for industrial applications, with IP67)
- Table tripod
- Process interface cable incl. terminal block (1 m)
- Software package PIX Connect
- Operators manual
- Aluminum case
- PI 450i/ 450i G7/ 640i/ 640i G7 only: robust hard transport case (IP67)

1.4 Maintenance



Never use cleaning compounds which contain solvents (neither for the lens nor for the housing).

1.4.1 Cleaning

Blow off loose particles using clean compressed air. The lens surface can be cleaned with a soft, humid tissue (moistened with water) or a lens cleaner (e.g. Purosol or B+W Lens Cleaner).

1.5 Model overview

The cameras of the PI series are available in the following basic versions:

Model	Model code	Temperature range	Spectral range	Frame rate	Typical applications
PI 400i/ PI 450i	IR	-20 to 900 °C 200 to 1500 °C (optional)	8 – 14 µm	80 Hz	Real-time thermographic images in high speed; Detection of smallest temperature differences (PI 450i)
PI 450i G7	IR	200 to 1500 °C 150 to 900 °C	7.9 µm	80 Hz/ 27 Hz	Measurement of glass (with Line-Scanning mode)
PI 640i	IR	-20 to 900 °C 200 to 1500 °C (optional)	8 – 14 µm	32 Hz	Pin-sharp radiometric recordings in real time, Detection of smallest temperature differences
PI 640i G7	IR	200 to 1500 °C 150 to 900 °C	7.9 µm	32 Hz	Measurement of glass (with Line-Scanning mode)
PI 05M	IR	900 to 2450 °C	500 – 540 nm	Up to 1 kHz	Measurement of metallic surfaces, graphite or ceramics with short wavelengths
PI 08M	IR	575 to 1900 °C	780 – 820 nm	Up 1 kHz	Measurement of metallic surfaces, graphite or ceramics with short wavelengths, especially for laser applications
PI 1M	IR	450 to 1800 °C	0.85 – 1.1 µm	Up to 1 kHz	Measurement of metallic surfaces, graphite or ceramics with short wavelengths

Table 1: Model overview

2 Technical Data

2.1 General specifications

Environmental rating:	IP67 (NEMA-4)
Ambient temperature:	0...50 °C [PI 400i/ PI 640i/ PI 640i G7] 5...50 °C [PI 05M/ PI 08M/ PI 1M] 0...70 °C [PI 450i/ PI 450i G7]
Storage temperature:	-40...70 °C (-40...85 °C [PI 450i/ PI 450i G7])
Relative humidity:	10...95 %, non-condensing
Material (housing):	Aluminum, anodized
Dimensions:	PI 400i/ PI 450i (450i G7): 46 x 56 x 68 - 77 mm (depending on lens and focus position) PI 640i (640i G7): 46 x 56 x 76 - 100 mm (depending on lens and focus position) PI 640i microscope optics: 46 x 56 x 119 – 126 mm (depending on focus position) PI 05M/ PI 08M/ PI 1M: 46 x 56 x 88 - 129 mm (depending on lens and focus position)
Weight:	PI 400i/ PI 450i (450i G7): 237-251 g (depending on lens) PI 640i (640i G7): 269-340 g (depending on lens) PI 05M/ PI 08M/ PI 1M: 245-311 g (depending on lens) PI 640i microscope optics: 370 g

Cable length (USB 2.0):	1 m (standard), 3 m, 5 m, 10 m, 20 m
Vibration ¹⁾ :	IEC 60068-2-6 (sinus shaped) IEC 60068-2-64 (broadband noise)
Shock ¹⁾ :	IEC 60068-2-27 (25 G and 50 G)

1) Used standards for vibration and shock:

IEC 60068-1:1988 + Corr. 1988 + A1: 1992	DIN EN 60068-1:1995-03
„Umweltprüfungen - Teil 1: Allgemeines und Leitfaden“	
IEC 60068-2-6:2007	DIN EN 60068-2-6; VDE 0468-2-6:2008-10
„Umgebungseinflüsse - Teil 2-6: Prüfverfahren - Prüfung Fc: Schwingen (sinusförmig)“	
IEC 60068-2-27:2008	DIN EN 60068-2-27; VDE 0468-2-27:2010-02
„Umgebungseinflüsse - Teil 2-27: Prüfverfahren - Prüfung Ea und Leitfaden: Schocken“	
IEC 60068-2-47:2005	DIN EN 60068-2-47:2006-03
„Umgebungseinflüsse - Teil 2-47: Prüfverfahren - Befestigung von Prüflingen für Schwing-, Stoß- und ähnliche dynamische Prüfungen“	
IEC 60068-2-64:2008	DIN EN 60068-2-64; VDE 0468-2-64:2009-04
„Umgebungseinflüsse - Teil 2-64: Prüfverfahren - Prüfung Fh: Schwingen, Breitbandrauschen (digital geregelt) und Leitfaden“	

Figure 1: Used standards

Stress program (camera in operation):

Shock, half sinus 25 G – testing Ea 25 G (acc. IEC 60068-2-27)			
Acceleration	245 m/s ²	(25 G)	
Pulse duration	11 ms		
Number of directions	6	(3 axes with 2 directions each)	
Duration	600 Shocks	(100 Shocks each direction)	
Shock, half sinus 50 G – testing Ea 50 G (acc. IEC 60068-2-27)			
Acceleration	490 m/s ²	(50 G)	
Pulse duration	11 ms		
Number of directions	6	(3 axes with two directions each)	
Duration	18 Shocks	(3 Shocks each direction)	
Vibration, sinus shaped – testing Fc (acc. IEC60068-2-6)			
Frequency range	10 - 500 Hz		

Acceleration	29.42 m/s ²	(3 G)	
Frequency change	1 Octave/ min		
Number of axes	3		
Duration	1:30 h	(3 x 0.30 h)	
Vibration, broadband noise – testing Fh (acc. IEC60068-2-64)			
Frequency range	10 - 2000 Hz		
Acceleration	39.3 m/s ²	(4.01 G _{RMS})	
Frequency spectrum	10 - 106 Hz	0.9610 (m/s ²) ² /Hz	(0.010 G ² /Hz)
	106 - 150 Hz	+6 dB/ Octave	
	150 - 500 Hz	1.9230 (m/s ²) ² /Hz	(0.020 G ² /Hz)
	500 - 2000 Hz	-6 dB/ Octave	
	2000 Hz	0.1245 (m/s ²) ² /Hz	(0.00126 G ² /Hz)
Number of axes	3		
Duration	3 h	(3 x 1 h)	

2.2 Electrical specifications

Power Supply:	5 VDC (powered via USB 2.0 interface)
Current draw:	Max 500 mA
AO: Output Standard Process Interface (PIF out)	0 - 10 V (Main measure area, measure area, internal temperature, flag status, recording status, line scan status, alarm, frame sync, fail-safe, external communication) ▶ Appendix F – Wiring diagrams PIF]
AI: Input Standard Process Interface (PIF in)	0 - 10 V (Emissivity, ambient temperature, reference temperature, uncommitted value, flag control, triggered snapshots, triggered recording, triggered linescanner, triggered event grabber, reset peak-/value-hold, switch temperature range) ▶ Appendix F – Wiring diagrams PIF]
DI: Digital Input Standard Process Interface	Flag control, , triggered snapshots, triggered recording, triggered linescanner, triggered event grabber, reset peak-/value-hold, switch temperature range ▶ Appendix F – Wiring diagrams PIF]
Digital interface:	USB 2.0

2.3 Measurement specifications

	PI 400i	PI 450i	PI 450i G7
Temperature ranges	-20...100 °C; 0...250 °C; (20) 150...900 °C ¹⁾ ; Option: 200...1500 °C		200...1500 °C 150...900 °C
Sighting range / low energy range ²⁾	-		0...250 °C
Spectral range	8 - 14 μm		7.9 μm
Detector	UFPA, 382 x 288 pixel @ 80 Hz (switchable to 27 Hz)		
Lenses (FOV)	18° x 14° (F-number=1,1), 29° x 22° (F-number=0,9), 53° x 38° (F-number=0,9); 80° x 54° (F-number=0,9)		
System accuracy ³⁾	±2°C or ±2 %		
Temperature coefficient ⁴⁾	± 0,05 %/K		
Thermal sensitivity (NETD):	75 mK ⁵⁾ with 29°, 53° and 80°; 0.1 K ⁵⁾ with 18°	40 mK ⁵⁾ with 29°, 53° and 80°; 60 mK ⁵⁾ with 18°	150 mK (T _{obj} = 650 °C) with 29°, 53°, 80° 175 mK (T _{obj} = 650 °C) with 18°
Warm-up time	10 min		
Emissivity	0.100...1.100		
Software / App	PIX Connect / IRmobile		

¹⁾ Accuracy statement effective from 150 °C

²⁾ The sighting range is used to align the G7 cameras; at $\epsilon < 1$ and activation of the extended temperature range a temperature measurement up to 1500 °C is possible

³⁾ At ambient temperature 23±5 °C; whichever is greater

⁴⁾ For T_{Amb} 10...50 °C and $T_{Obj} \leq 500$ °C; otherwise: ± 0.1 K/K or 0.1%/K (whichever is greater)

⁵⁾ Value is valid at 40 Hz and 25 °C room temperature

	<u>PI 640i</u>	<u>PI 640i G7</u>
Temperature ranges	-20...100 °C; 0...250 °C; (20) 150...900 °C ¹⁾ Option: 200...1500 °C	200...1500 °C 150...900 °C
Sighting range / low energy range ²⁾	-	0...250 °C
Spectral range	8 - 14 μm	7,9 μm
Detector	UFPA, 640 x 480 Pixel @ 32 Hz 640 x 120 Pixel @ 125Hz	
Lenses (FOV)	15° x 11° (F-number=1); 33° x 25° (F-number=0,8); 60° x 45° (F-number=0,8); 90° x 64° (F-number=0,8)	
Microscope lens (FOV)	12° x 9° (F=1,1)	-
System accuracy ³⁾	±2°C or ±2 %	
Temperature coefficient ⁴⁾	± 0,05 %/K	
Thermal sensitivity (NETD):	40 mK	80 mK
Warm-up time	10 min	
Emissivity	0.100...1.100	
Software / App	PIX Connect / IRmobile	

¹⁾ Accuracy statement effective from 150 °C

²⁾ The sighting range is used to align the G7 cameras; at $\epsilon < 1$ and activation of the extended temperature range a temperature measurement up to 1500 °C is possible

³⁾ At ambient temperature 23 ± 5 °C; whichever is greater

⁴⁾ For T_{Amb} 10...50 °C and $T_{Obj} \leq 500$ °C; otherwise: ± 0.1 K/K or 0.1%/K (whichever is greater)

	PI 05M	PI 08M	PI 1M
Temperature ranges	900 ... 2450 °C (27 Hz mode) 950 ... 2450 °C (80 Hz and 32 Hz mode) 1100 ... 2450 °C (1 kHz mode)	575 ... 1900 °C (27 Hz mode) 625 ... 1900 °C (80 Hz- and 32 Hz-mode) 750 ... 1900 °C (1 kHz mode)	450 ¹⁾ ...1800 °C (27 Hz mode) 500 ¹⁾ ...1800 °C (80 Hz and 32 Hz mode) 600 ¹⁾ ...1800 °C (1 kHz mode)
Spectral range	500 - 540 nm	780 – 820 nm	0,85 - 1,1 µm
Detector	CMOS, 764 x 480 pixel @ 32 Hz 382 x 288 pixel @ 80 Hz/ (switchable to 27 Hz) 72x56 pixel @ 1 kHz (1 ms real-time analog output (0-10 V) from 8x8 pixel (freely selectable)) 764 x 8 Pixel @ 1 kHz (fast line scanning-mode, 1 ms real-time analog output (0-10 V) from 8x8 pixel (freely selectable))		
Lenses (FOV) ²⁾	FOV@764x480 px: 26°x 16° (F-number=1,4) FOV@382x288 px: 13°x 10°	FOV@764x480 px: 26°x 16° (F-number=1,4), 39°x 25° (F-number=1,4) FOV@382x288 px: 13°x 10°, 20°x 15°	FOV@764x480 px: 9°x 5° (F-number=2,8), 13°x 8° (F-number=2,4), 26°x16° (F-number=1,4), 39°x 25° (F-number=1,4) FOV@382x288 px: 4°x 3°, 7°x 5°, 13°x 10°, 20°x 15°
System accuracy ³⁾	For object temperature < 2000 °C: ±1 % of reading for 27/32/80 Hz ±1,5 % of reading for 1 kHz For object temperature > 2000 °C: ±2 % of reading for 27/32/80 Hz ±2,5 % of reading for 1 kHz	For object temperature < 1500 °C: ±1 % of reading for 27/32/80 Hz ±1,5 % of reading for 1 kHz For object temperature > 1500 °C: ±2 % of reading for 27/32/80 Hz ±2,5 % of reading for 1 kHz	For object temperature < 1400 °C: ±1 % of reading for 27/32/80 Hz ±1,5 % of reading for 1 kHz For object temperature < 1600 °C: ±2 % of reading for 27/32/80 Hz ±2,5 % of reading for 1 kHz
Thermal sensitivity (NETD) ⁴⁾ :	< 2 K (< 1400 °C) < 4 K (> 1400 °C)	< 2 K (< 1000 °C) < 4 K (> 1000 °C)	< 2 K (< 900 °C) < 4 K (< 1400 °C)
Warm-up time	10 min		

Emissivity	0.100...1.100
Software / App	PIX Connect / IRmobile

- ¹⁾ +75 °C start temperature for optics with focal length $f= 50 \text{ mm}$, $f= 75 \text{ mm}$
- ²⁾ An additionally purchased lens for the PI 05M/ 08M/ 1M camera comes with the corresponding protective tube
- ³⁾ At an ambient temperature of 25 ° C
- ⁴⁾ Specified NETD value applies to all frequencies

2.4 Optical specifications



Make sure that the focus of thermal channel is adjusted correctly. If necessary, focus the thermal imaging camera with the optics (**Figure 2**). The turning out of the optics leads to the focus setting "near" and the turning in of the lens to the focus setting "infinity".



Figure 2: Focusing by turning the exterior lens ring of camera



Figure 3: PI 05M/ PI 08M / PI 1M



For the PI 05M, PI 08M and PI 1M camera, you must first unscrew the protective tube in order to be able to focus the camera (**Figure 3**).

The variety of different lenses offers the possibility to precisely measure objects in different distances. We offer lenses for close, standard distances and large distances. Different parameters are important if using infrared cameras. They display the connection between the distance of the measured object and the size of the pixel (**Table 2**).

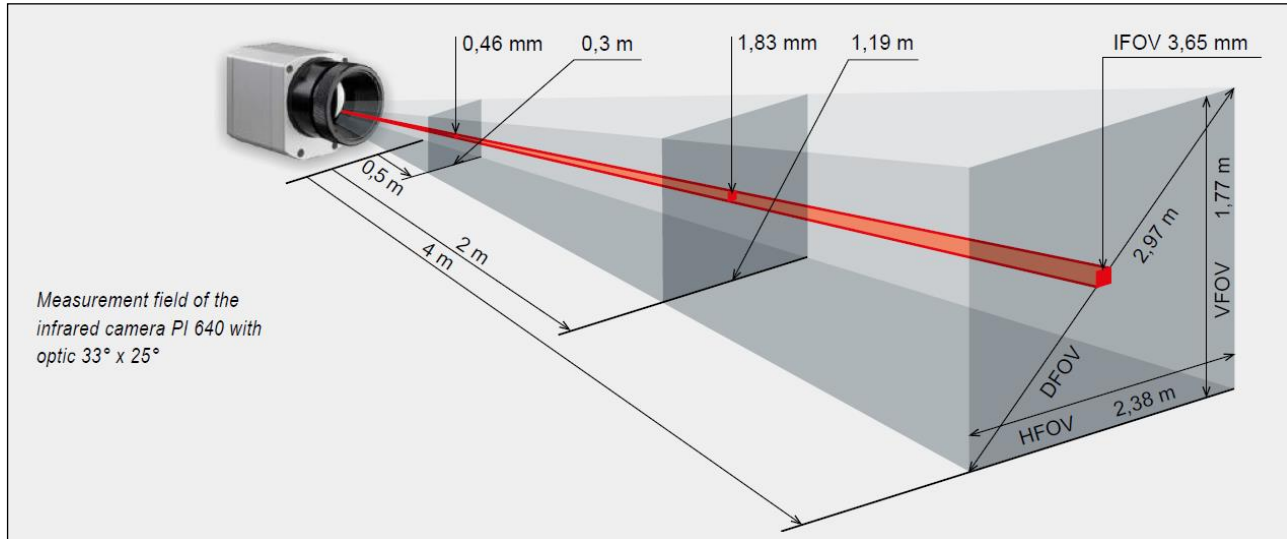

Figure 4: Measurement field of the infrared camera optris® PI 640i representing the 33° x 25° lens

- **HFOV:** Horizontal enlargement of the total measuring at object level
- **VFOV:** Vertical enlargement of the total measuring at object level
- **IFOV:** Size at the single pixel at object level
- **DFOV:** Diagonal dimension of the total measuring field at object level
- **MFOV:** Recommended, smallest measured object size of 3 x 3 pixel

Geometric resolution for ideal temperature measurement

When designing optics for measuring IR cameras, special attention must be paid to the quality of detail contrast with which an object can be represented in the image. This is described by the modulation transfer function (MTF). Since in contrast to visual cameras, with IR cameras the thermal contrast is of more interest, this is used together with the slit response function (SRF). The result is determined by the number of pixels an object needs to fill to allow its temperature be to be measured exactly. In high-performance infrared optical systems as used by Optris, this is **3x3 pixels**, with lower quality optical systems, in some circumstances as many as 10x10 pixels may be required, to receive **90 %** of the energy. A high-performance camera lens also allows a larger measuring distance with the same number of pixels of the detector, or the precise temperature

measurement of smaller structures and objects. The **3×3 pixel** geometry is described as **MFOV (measurement field of view)** - one single pixel on the object surface is described as **IFOV (instantaneous field of view)**. The MFOV is comparable with the measuring spot definition with infrared thermometers.

The following tables with examples showing what spot sizes and pixel sizes will be reached in which distance. For individual configuration there are different lenses available. Wide angle lenses have a radial distortion due to their large opening angle; the software PIX Connect has an algorithm which corrects this distortion. As an alternative to the tables below, the [optics calculator](#) can also be used on the optris website or via the [optris calculator app](#). The app can be downloaded for free from the Google Play Store (see QR code).

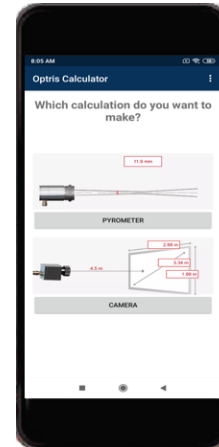

Table 2:

PI 400i / PI450i PI450i G7	Focal length [mm]	Minimum measurement distance*	Angle	Distance to measurement object [m]												
					0,05	0,1	0,2	0,3	0,5	1	2	4	6	10	30	100
382 x 288 px O29 Standard lens	13	0,35 m	29 °	HFOV [m]	0,03	0,06	0,11	0,17	0,27	0,53	1,06	2,11	3,16	5,26	15,8	52,5
			22 °	VFOV [m]	0,03	0,04	0,08	0,12	0,20	0,39	0,78	1,55	2,32	3,86	11,6	38,5
			37 °	DFOV [m]	0,04	0,07	0,14	0,21	0,34	0,66	1,31	2,62	3,92	6,52	19,5	65,1
			1,4 mrad	IFOV [mm]	0,09	0,16	0,30	0,43	0,71	1,39	2,77	5,53	8,27	13,8	41,2	137
O18 Telephoto lens	20	0,45 m	18 °	HFOV [m]			0,07	0,10	0,16	0,33	0,66	1,32	1,96	3,26	9,77	32,5
			14 °	VFOV [m]			0,05	0,08	0,13	0,25	0,50	0,99	1,49	2,48	7,42	24,7
			23 °	DFOV [m]			0,09	0,13	0,21	0,41	0,83	1,65	2,46	4,09	12,3	40,9
			0,9 mrad	IFOV [mm]			0,18	0,27	0,43	0,86	1,74	3,44	5,13	8,53	25,6	85,2
O53 Wide angle lens	8	0,25 m	53 °	HFOV [m]	0,06	0,11	0,21	0,31	0,51	1,01	2,00	3,99	5,98	10,0	29,9	100
			38 °	VFOV [m]	0,04	0,08	0,14	0,21	0,35	0,70	1,39	2,77	4,15	6,92	20,8	69,2
			65 °	DFOV [m]	0,07	0,13	0,25	0,37	0,62	1,23	2,44	4,86	7,29	12,1	36,4	121
			2,7 mrad	IFOV [mm]	0,15	0,28	0,54	0,80	1,33	2,63	5,24	10,5	15,7	26,1	78,2	261
O80 Super wide angle	6	0,2 m	80 °	HFOV [m]	0,09	0,17	0,33	0,49	0,81	1,61	3,23	6,50	9,81	16,6	49,9	166
			54 °	VFOV [m]	0,06	0,11	0,21	0,31	0,52	1,03	2,04	4,07	6,13	10,2	30,6	102
			96 °	DFOV [m]	0,11	0,21	0,39	0,58	0,96	1,91	3,82	7,67	11,6	19,5	58,5	195
			4,2 mrad	IFOV [mm]	0,24	0,46	0,87	1,29	2,11	4,21	8,47	17,0	25,7	43,6	131	435

* Note: The accuracy of measurement can be outside of the specifications for distances below the defined minimum distance.

PI 640i / PI 640i G7	Focal length [mm]	Minimum measurement distance*	Angle	Distance to measurement object [m]												
					0.05	0.1	0.2	0.3	0.5	1	2	4	6	10	30	100
640 x 480 px O33 Standard lens	19	0.2 m	33°	HFOV [m]		0.064	0.12	0.18	0.30	0.60	1.20	2.4	3.6	6.0	17.9	59.7
			25°	VFOV [m]		0.047	0.09	0.14	0.23	0.45	0.9	1.8	2.7	4.5	13.4	44.5
			42°	DFOV [m]		0.079	0.15	0.23	0.38	0.75	1.5	3.0	4.5	7.5	22.4	74.5
			0.9 mrad	IFOV [mm]		0.1	0.2	0.3	0.5	0.9	1.9	3.7	5.6	9.3	28.0	93.3
O15 Telephoto lens	42	0.5 m	15°	HFOV [m]					0.14	0.27	0.53	1.0	1.6	2.6	7.8	26.2
			11°	VFOV [m]					0.10	0.20	0.40	0.8	1.2	2.0	5.9	19.6
			19°	DFOV [m]					0.17	0.33	0.66	1.3	2.0	3.3	9.8	32.7
			0.4 mrad	IFOV [mm]					0.2	0.4	0.8	1.6	2.4	4.1	12.3	40.9
O60 Wide angle lens	11	0.2 m	60°	HFOV [m]	0.07	0.13	0.24	0.35	0.60	1.2	2.3	4.7	7.0	11.7	34.9	116.4
			45°	VFOV [m]	0.05	0.09	0.17	0.26	0.42	0.8	1.7	3.3	5.0	8.3	24.9	82.9
			75°	DFOV [m]	0.09	0.16	0.30	0.44	0.73	1.4	2.9	5.7	8.6	14.3	42.9	142.9
			1.9 mrad	IFOV [mm]	0.1	0.2	0.4	0.6	0.9	1.8	3.7	7.3	10.9	18.2	54.6	182
O90 Super wide angle lens	8	0.2 m	90°	HFOV [m]	0.11	0.22	0.42	0.62	1.0	2.0	4.0	8.1	12.1	20.2	60.4	201.4
			64°	VFOV [m]	0.07	0.14	0.26	0.39	0.6	1.3	2.5	5.0	7.6	12.6	37.7	125.7
			110°	DFOV [m]	0.14	0.26	0.49	0.73	1.2	2.4	4.8	9.5	14.2	23.8	71.3	237.4
			3.2 mrad	IFOV [mm]	0.2	0.3	0.7	1.0	1.6	3.2	6.3	12.6	18.9	31.5	94.4	315

* Note: The accuracy of measurement can be outside of the specifications for distances below the defined minimum distance.

Microscope optics PI 640i 640 x 480 px	Focal length [mm]	Minimum measurement distance*	Angle	Distance to measurement object [m]			
					0.08	0.09	0.1
MO44 Microscope optics	44.2	0.08 m	12°	HFOV [m]	0.018	0.021	0.023
			9°	VFOV [m]	0.014	0.016	0.017
			15°	DFOV [m]	0.023	0.026	0.029
			0.36 mrad	IFOV [mm]	0.028	0.032	0.036

* Note: The accuracy of measurement can be outside of the specifications for distances below the defined minimum distance.

PI 05M/08M/1M	Focal length [mm]	Minimum focussing distance*	Minimum measurement distance*	Angle	Distance to measurement object [m]											
					0,1	0,2	0,3	0,5	1	2	4	6	10	30	100	
768 x 480 px O27 Standard optics	25	0,1 m	0,3 m	27°	HFOV [m]	0,052	0,100	0,15	0,25	0,48	0,97	1,9	2,9	4,8	14,5	48,4
				17°	VFOV [m]	0,03	0,06	0,09	0,15	0,30	0,60	1,2	1,8	3,0	9,0	30,1
				32°	DFOV [m]	0,06	0,12	0,18	0,29	0,57	1,14	2,3	3,4	5,7	17,1	57,0
				0,6 mrad	IFOV [mm]*	0,1	0,1	0,2	0,3	0,6	1,3	2,5	3,8	6,3	18,9	63,0
O9 Supertele optics	75	1,0 m	1,0 m	9°	HFOV [m]					0,15	0,30	0,61	0,9	1,5	4,6	15,4
				6°	VFOV [m]					0,09	0,19	0,38	0,6	1,0	2,9	9,6
				10°	DFOV [m]					0,17	0,36	0,72	1,08	1,8	5,4	18,1
				0,2 mrad	IFOV [mm]*					0,2	0,4	0,8	1,2	2,0	6,0	20,0
O13 Tele optics	50	0,5 m	0,5 m	13°	HFOV [m]				0,11	0,23	0,46	0,94	1,41	2,35	7,05	23,5
				8°	VFOV [m]				0,07	0,14	0,29	0,59	0,88	1,5	4,4	14,7
				16°	DFOV [m]				0,13	0,27	0,55	1,1	1,7	2,8	8,3	27,7
				0,3 mrad	IFOV [mm]*				0,15	0,30	0,60	1,2	1,8	3,1	9,2	30,6
O41 Wideangle optics	16	0,1 m	0,3 m	41°	HFOV [m]	0,082	0,156	0,23	0,38	0,75	1,49	3,0	4,5	7,4	22,3	74,2
				25°	VFOV [m]	0,050	0,09	0,14	0,23	0,45	0,9	1,8	2,7	4,5	13,4	44,7
				48°	DFOV [m]	0,10	0,18	0,27	0,44	0,88	1,7	3,5	5,2	8,7	26,0	86,6
				1,0 mrad	IFOV [mm]*	0,1	0,2	0,3	0,5	1,0	1,9	3,9	5,8	9,7	29,0	96,6

* Note: The accuracy of measurement can be outside of the specifications for distances below the defined minimum distance.

PI 05M is only available with O27 optics and PI 08M is only available with O27 and O41 optics

PI 05M PI 08M PI 1M 382 x 288 px	Focal length [mm]	Minimum focussing distance*	Minimum measurement distance*	Angle	Distance to measurement object [m]											
					0,1	0,2	0,3	0,5	1	2	4	6	10	30	100	
O27 Standard optics	25	0,1 m	0,3 m	14°	HFOV [m]	0,026	0,050	0,07	0,12	0,24	0,48	1,0	1,4	2,4	7,2	24,2
				11°	VFOV [m]	0,02	0,04	0,06	0,09	0,18	0,36	0,7	1,1	1,8	5,5	18,2
				17°	DFOV [m]	0,03	0,06	0,09	0,15	0,31	0,60	1,2	1,8	3,0	9,0	30,3
				0,6 mrad	I FOV [mm]*	0,1	0,1	0,2	0,3	0,6	1,3	2,5	3,8	6,3	18,9	63,4
O9 Supertele optics	75	1,0 m	1,0 m	4°	HFOV [m]					0,07	0,15	0,29	0,4	0,8	2,3	7,7
				3°	VFOV [m]					0,06	0,12	0,23	0,4	0,6	1,8	5,8
				6°	DFOV [m]					0,09	0,19	0,37	0,56	1,0	2,9	9,7
				0,2 mrad	I FOV [mm]*					0,2	0,4	0,8	1,2	2,0	6,0	20,1
O13 Tele optics	50	0,5 m	0,5 m	7°	HFOV [m]				0,06	0,12	0,24	0,47	0,70	1,19	3,57	11,9
				5°	VFOV [m]				0,04	0,09	0,18	0,36	0,54	0,9	2,7	8,9
				9°	DFOV [m]				0,07	0,15	0,29	0,6	0,9	1,5	4,5	14,9
				0,3 mrad	I FOV [mm]*				0,15	0,31	0,62	1,2	1,8	3,1	9,3	31,1
O41 Wideangle optics	16	0,1 m	0,3 m	20°	HFOV [m]	0,040	0,075	0,11	0,18	0,36	0,72	1,4	2,1	3,6	10,7	35,6
				15°	VFOV [m]	0,029	0,06	0,08	0,14	0,27	0,5	1,1	1,6	2,7	8,1	27,0
				25°	DFOV [m]	0,05	0,09	0,14	0,23	0,45	0,9	1,8	2,7	4,5	13,4	44,7
				1,0 mrad	I FOV [mm]*	0,1	0,2	0,3	0,5	1,0	1,9	3,7	5,6	9,3	28,0	93,3

* Note: The accuracy of measurement can be outside of the specifications for distances below the defined minimum distance.

PI 05M is only available with O27 optics and PI 08M is only available with O27 and O41 optics

3 Mechanical Installation

3.1 Dimensions

The PI is equipped with two metric M4 thread holes on the bottom side (6 mm depth) and can be installed either directly via these threads or with help of the tripod mount (also on bottom side).



The tightening torque of the M4 screws for mounting the PI camera should be between **1 ... 1.5 Nm** and must not exceed **2 Nm**.

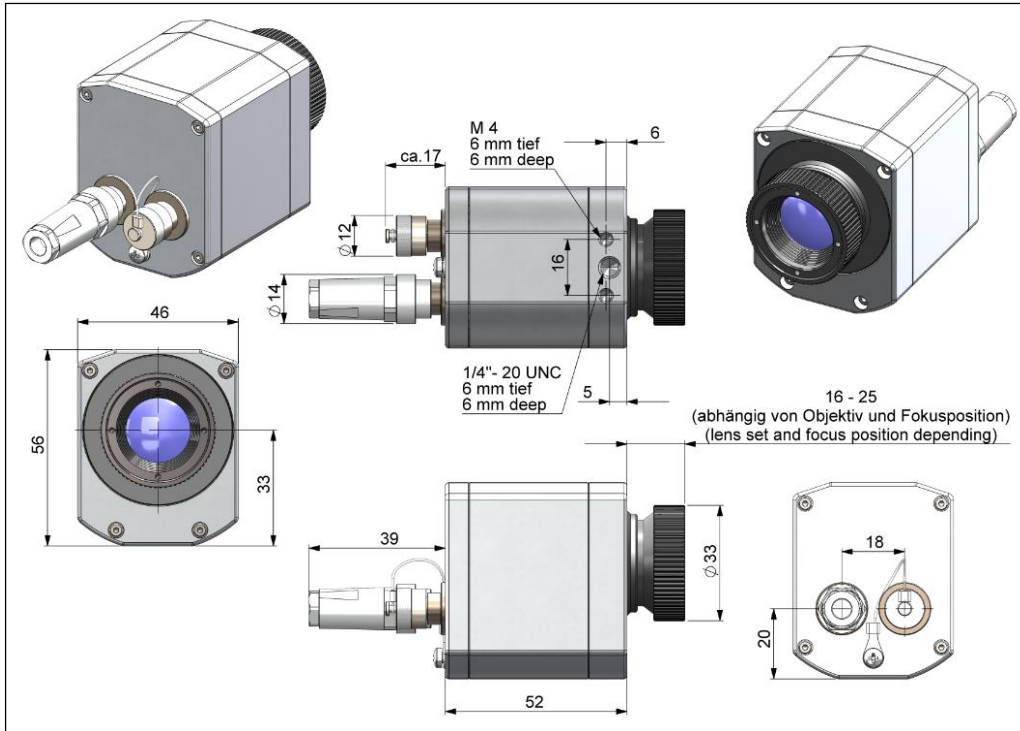

Figure 5: PI 400i/ PI 450i/ PI 450i G7, dimensions [mm]

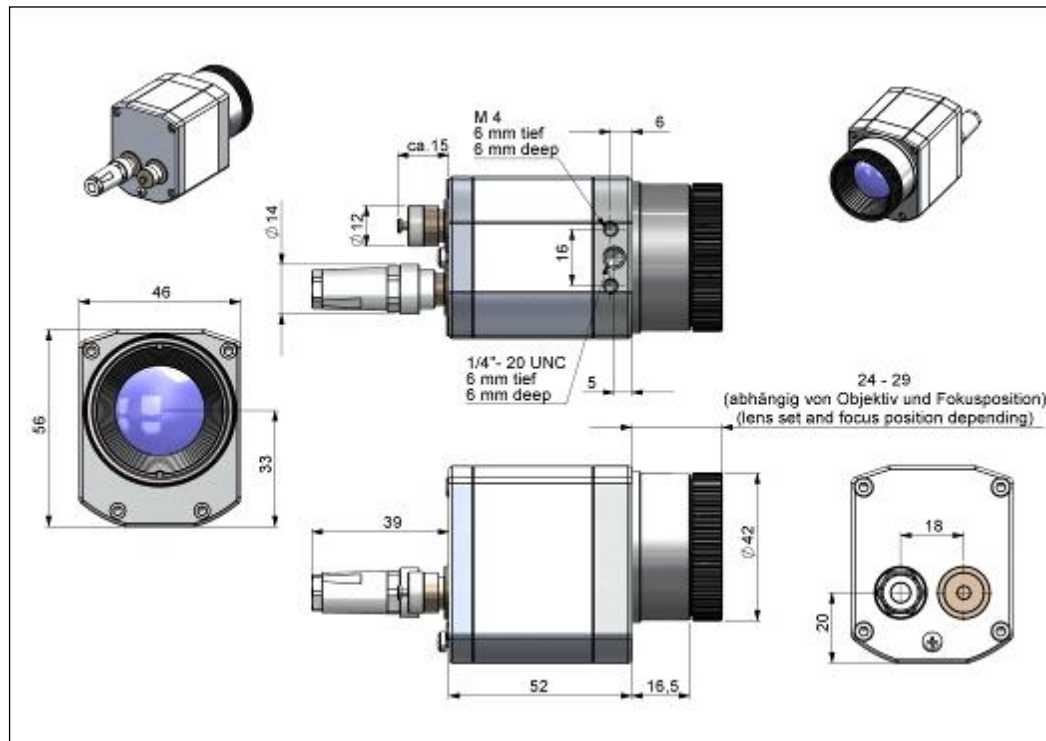

Figure 6: PI 640i/ PI 640i G7, optics 29°/33° & 53°/60°, dimensions [mm]

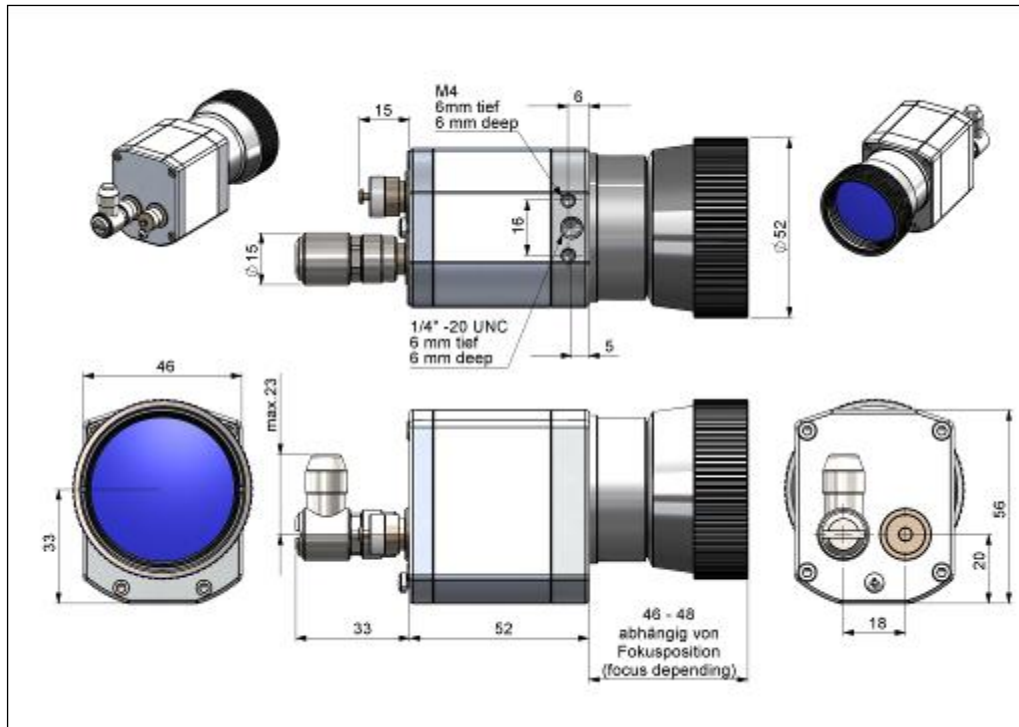

Figure 7: PI 640i/ PI 640i G7, optics 13°/15°, dimensions [mm]

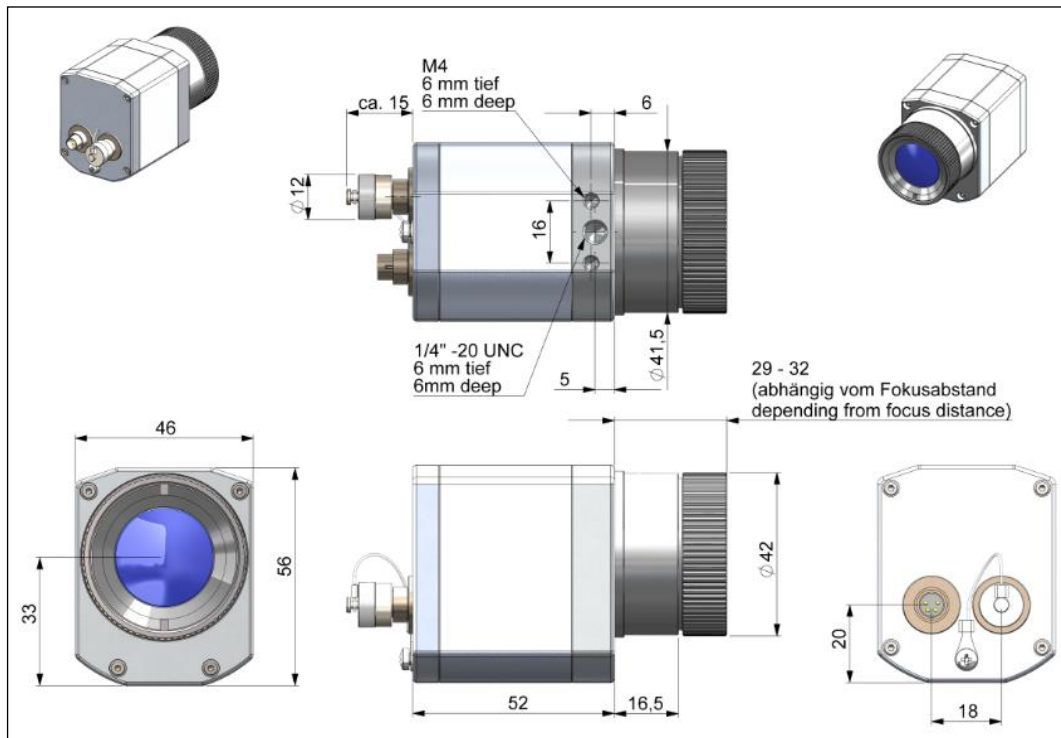

Figure 8: PI 640i/ PI 640i G7, optics 80°/90°, dimensions [mm]

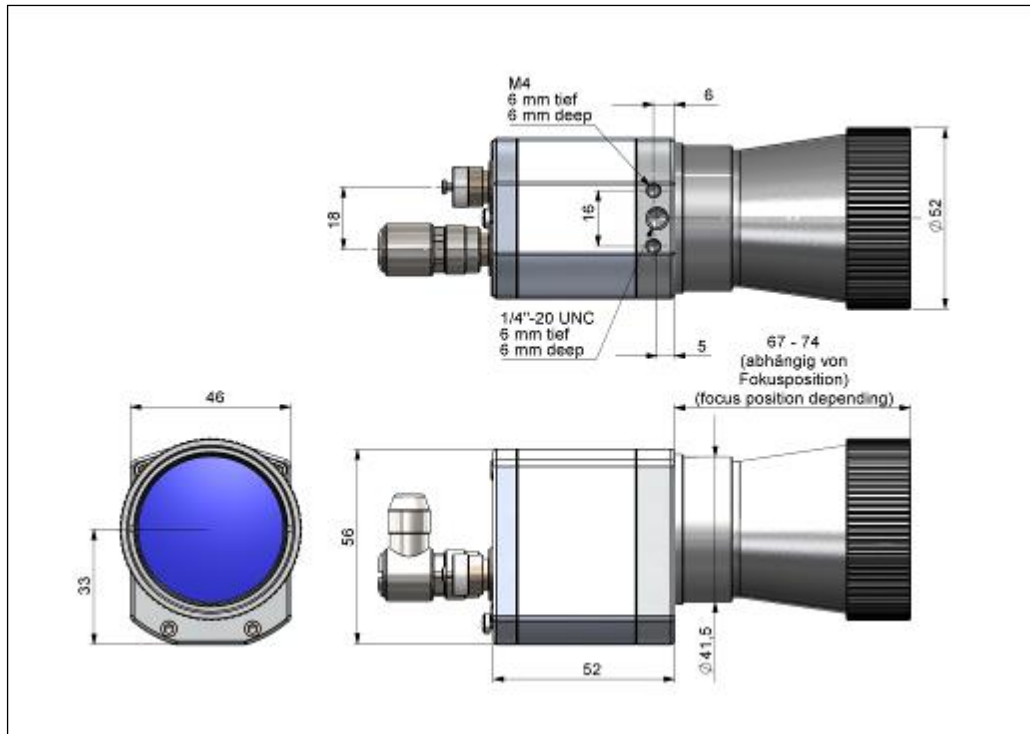

Figure 9: PI 640i, microscope optics 10°/12°, dimensions [mm]

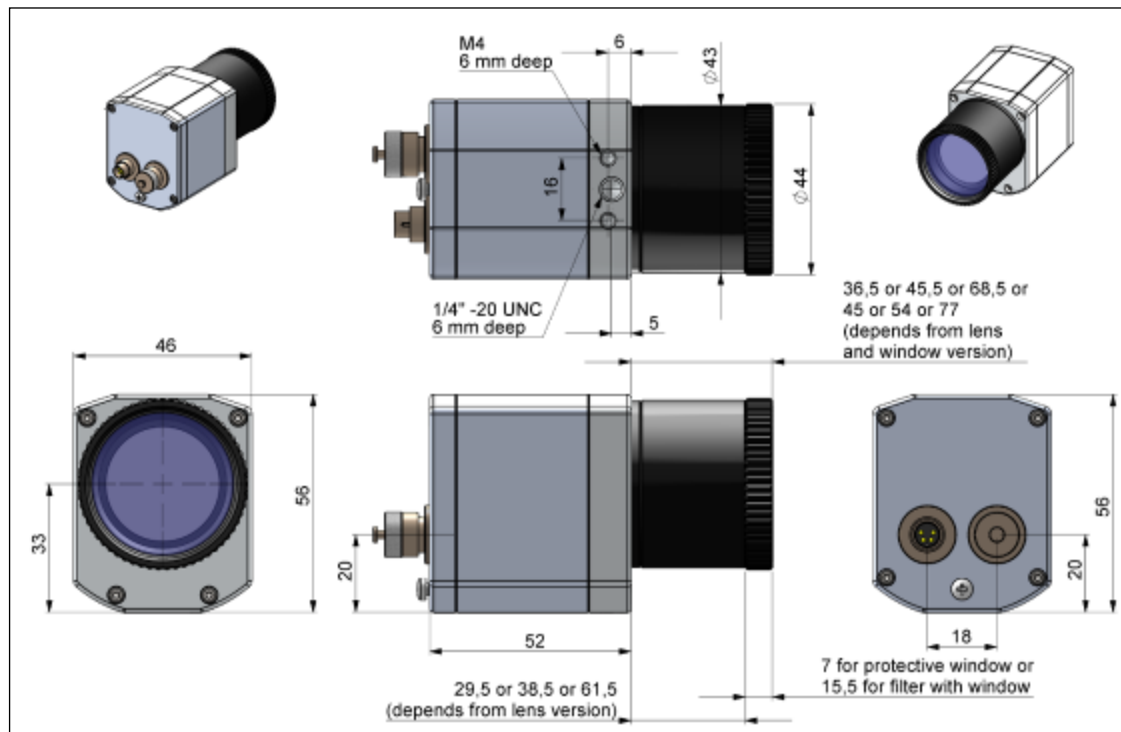

Figure 10: PI 05M/ PI 08M/ PI 1M, dimensions [mm]

3.2 Changing the lens

The PI camera is offered with several different lenses¹⁾ (lenses depending on the camera variant). To change a lens, rotate it as shown below. For the PI 05M, PI 08M and PI 1M, the protective tube must first be turned off (see **Figure 3**).



Figure 11: Change lens for PI 400i/450i/ 640i



Figure 12: Change lens for PI 05M/08M/ 1M



Figure 13: Inserting the lens

To get the best possible measurements when inserting the lens into the camera body, make sure that the label on the lens is screwed in at the same height as the label from the housing (see **Figure 13**).

¹⁾ An additionally purchased lens for the PI 05M/ 08M/ 1M camera comes with the corresponding protective tube

3.3 Fixing the focus of the lens (only for PI 05M/ 08M/ 1M)

With the PI 05M, PI 08M and PI 1M, it is possible to fix the focus of the lens. To do this, unscrew the protective tube of the camera (see **Figure 3**). There are three small holes on the lens. Take the three screws that are included and attach them to the three holes. The focus of the lens is now fixed. Alternatively, the two knurled screws supplied can also be used.



Figure 14: Lens for PI 05M/ 08M/ 1M



Figure 15: Fixing the focus for PI 05M/ 08M/ 1M

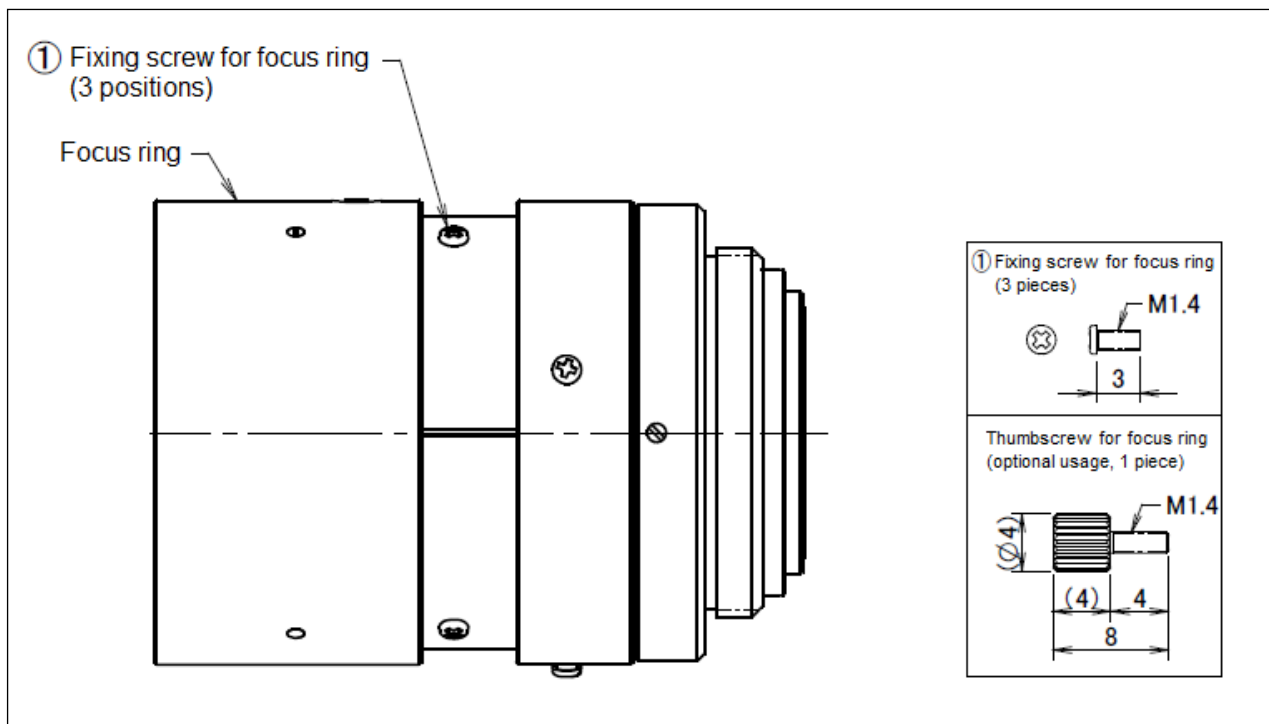

Figure 16: Focusing screws for focus ring

3.4 Mounting accessories (optional)

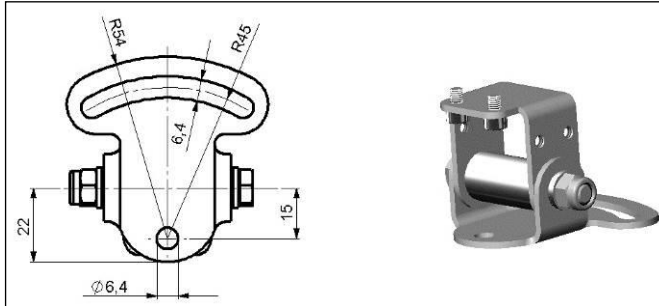

Figure 17: Mounting base, stainless steel, adjustable in 2 axes [Part No.: ACPIMB]

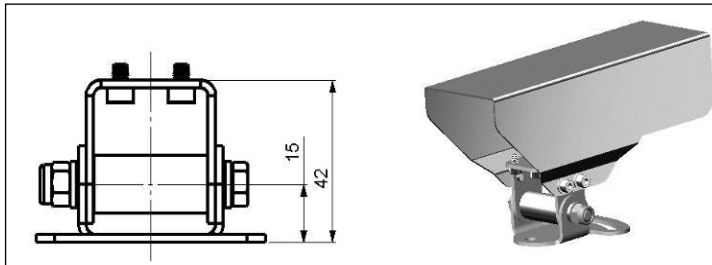

Figure 18: Protective housing, stainless steel, Incl. Mounting base [Part No.: ACPIPH]

3.5 High temperature accessories

3.5.1 CoolingJacket Advanced



- The CoolingJacket Advanced is available as Standard Version and Extended Version.
- The IR camera can be used at ambient temperature up to 50 °C (up to 70 °C with PI 450i/PI 450i G7). For higher temperatures (up to 315 °C) the CoolingJacket Advanced is provided.
- For detailed information see installation manual.

Standard Version

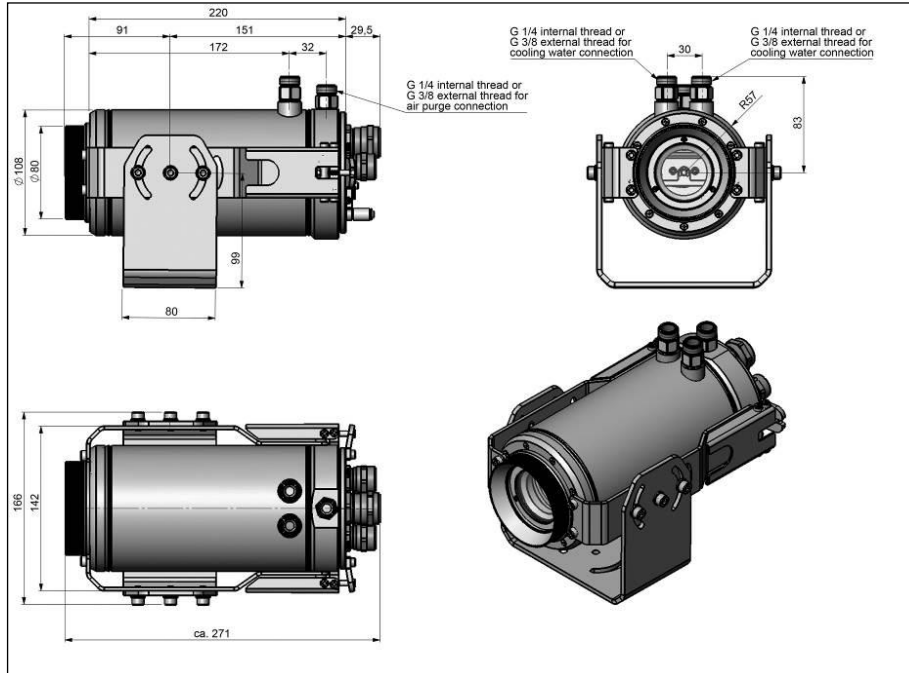

Figure 19: CoolingJacket Advanced [Part No.: ACPIxxxCJAS], Standard Version - Dimensions

Extended Version



The Extended Version is provided for applications of the PI series with the PI Netbox and industrial PIF or the USB Server Gigabit and industrial PIF. Both PI Netbox and industrial PIF or USB Server Gigabit and industrial PIF can be integrated in the CoolingJacket.



Figure 20: Cooling Jacket Advanced (Extended Version) with PI Netbox and industrial PIF



Figure 21: Cooling Jacket Advanced (Extended Version) with USB-Server and industrial PIF

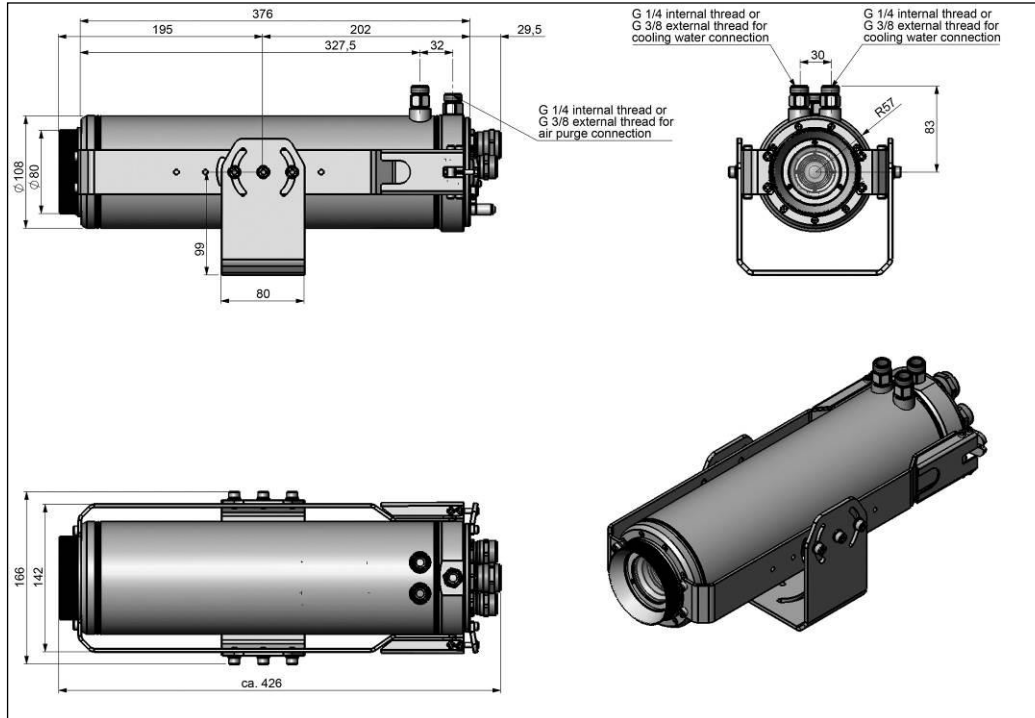

Figure 22: CoolingJacket Advanced [Part No.: ACPIxxxCJAE], Extended Version – Dimensions

3.5.2 Laminar air purge for CoolingJacket

Laminar air purge for front mounting of the CoolingJacket Advanced (Standard and Extended). Two different versions are available: One for standard IR camera applications [**Part-No.: ACCJAAPLS**] and the other for line scanning applications [**Part-No.: ACCJAAPLL**].

Those two versions are fitting to all focusing units with production date $\geq 01/2018$. A protective window (67 x 3 mm) must be ordered separately. If you like to mount the air purge on an older CJ, the focusing unit should be exchanged to the current version.



3.5.3 Outdoor protective housing



- The infrared camera PI and the USB server can also be used for outdoor applications by using the outdoor protective housing.
- The outdoor protective housing can be used for any PI camera (lenses up to 90° FOV)
- In addition, the industrial PIF can be installed as an accessory without housing
- Also available for CSLaser LT or CTlaser LT
- For detailed information see installation manual.



Figure 23: Outdoor protective housing for PI camera, USB server and industrial PIF

4 Electrical Installation

At the back side of the PI there are the two connector plugs. The left plug is for the USB cable. The right connector plug is only used for the process interface.

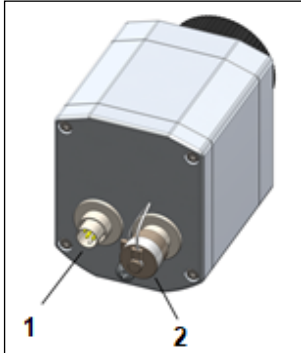

Figure 24: Backside of the camera with connectors

- 1 Plug for USB cable
- 2 Plug for PIF cable

4.1 Process interface



The process interface (electronics within cable as well as industrial interface) must be powered separately (5-24 VDC). Before switching on the power, the PIF cable must be connected to the camera.

The PI is equipped with a process interface (cable with integrated electronics and terminal block), which can be programmed via the software as an Analog Input (AI) and Digital Input (DI) in order to control the camera or as an Analog Output (AO) in order to control the process. The signal level is always 0-10 V (DI = 24 V).



The process interface can be activated choosing the following options:

Analog Input (AI):	Emissivity, ambient temperature, reference temperature, uncommitted value, flag control, triggered recording, triggered snapshots, triggered linescanner, triggered event grabber, reset peak-/value-hold, switch temperature range
Analog Output (AO):	Main measure area, measure area, internal temperature, flag status, recording status, line scan status, alarm, frame sync, fail-safe, external communication
Digital Input (DI):	Flag control, triggered snapshots, triggered recording, triggered linescanner, triggered event grabber, reset peak-/value-hold, switch temperature range

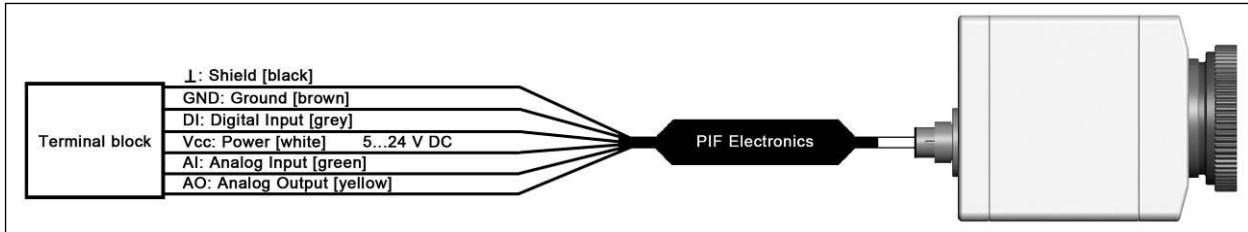

Figure 25: Configuration Standard Process Interface (PIF)

The standard process interface provides the following inputs and outputs:

<u>Name</u>	<u>Description</u>	<u>max range¹⁾/ status</u>
AI	Analog input	0-10 V ²⁾
DI	Digital input (active-low = 0...0,6 V)	24 V
AO	Analog output Alarm output	0-10 V 0/ 10 V

¹⁾ Depending on supply voltage; for 0-10 V on the AO the PIF has to be powered with min. 12 V.

²⁾ The AI is designed for max. 24 V, the voltage level above 10 V is not interpreted

4.1.1 PIN allocation

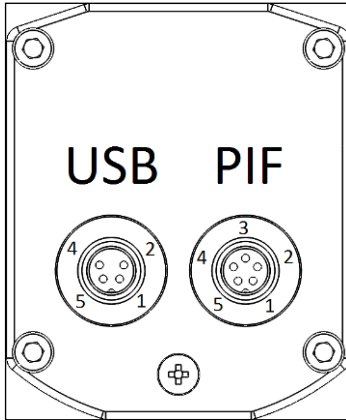

USB

1 VCC

2 GND

4 D -

5 D +

PIF

1 INT

2 SDA (I²C)

3 SCL (I²C)

4 DGND

5 3.3 V (Out)

Figure 26: Rear side of the camera

If the process interface of the camera is directly connected to external hardware¹⁾ (without using the supplied PIF cable) an activation of the field „Support proprietary PIF cable” in the menu **Tools/ Configuration/ Device (PIF)** in the PIX Connect software is necessary.

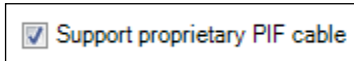

Figure 27: Support proprietary PIF cable



Consider that the input of the PIF is not protected if there is a direct PIF connection!
A voltage > 3 V on the INT pin will destroy the device!

¹⁾ We recommend using only a switching contact between INT and DGND as external hardware (button, relay).

4.1.2 Industrial Process Interface (optional)

For use in industrial environment the industrial process interface with 500 V AC_{RMS} isolation voltage between PI and process is available (connection box with IP65, 5 m, 10 m or 20 m standard or high temperature cable for camera connection, terminal for process integration). **[► Appendix F – Wiring diagrams PIF]**

Pin assignment PIF cable (industrial process interface)

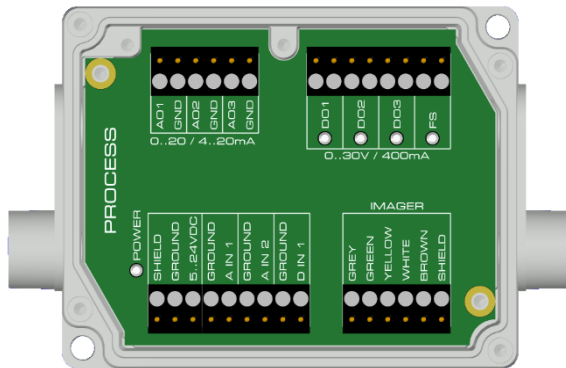

GREY	Interrupt
GREEN	SCL (I ² C)
YELLOW	SDA (I ² C)
WHITE	3.3 V
BROWN	GND
SHIELD	GND

Figure 28: Connections of the industrial Process Interface

The industrial process interface provides the following inputs and outputs:

<u>Name</u>	<u>Description</u>	<u>max range¹⁾/ status</u>
A IN 1 / 2	Analog input 1 and 2	0-10 V ²⁾
D IN 1	Digital input (active-low = 0...0,6 V)	24 V
AO1 / 2 / 3	Analog output 1, 2 and 3 Alarm output 1, 2 and 3	0/4-20 mA
DO1 / 2 / 3	Relay output 1, 2 and 3 ³⁾	open/ closed (red LED on) / 0...30 V, 400 mA
FS	Fail-safe relay	open/ closed (green LED on) / 0...30 V, 400 mA

¹⁾ depending on supply voltage; for 0-20 mA on the AO the PIF has to be powered with $min. 5V < (1.5 + working\ resistance * 0.021) < 24\ V$; Example: $R_{Load} = 500\ ohm \rightarrow U_{min} = 1.5 + 500 * 0.021 = 12\ V$, $R_{Load} = 100\ ohm \rightarrow U_{min} = 1.5 + 100 * 0.021 = 3.6\ V \rightarrow min. 5\ V$

²⁾ the AI is designed for max. 24 V, the voltage level above 10 V is not interpreted

³⁾ active if AO1, 2 or 3 is/ are programmed as alarm output



The alarm output can be configured as a threshold between **0-4 mA** for **no alarm** and between **10-20 mA** as **alarm**. For values outside the respective range, the relay does not switch on the DO.

The process interface has an integrated **fail-safe mode**. This allows to control conditions like interruption of cables, shut-down of the software etc. and to give out these conditions as an alarm. The time constant of the fail-safe is 1.5 seconds.

Controlled conditions on camera and software	Standard Process interface ACPIPIF	Industrial Process interface ACPIPIFMACBxx
Interruption USB cable to camera	✓	✓
Interruption data cable camera - PIF	✓	✓
Interruption power supply PIF	✓	✓
Shut-down of PIX Connect software	✓	✓
Crash of PIX Connect software	-	✓
Fail-Safe-Output	0 V at analog output (AO)	open contact (fail-safe relay)/ green LED off

4.2 Example for a Fail-Safe monitoring of the PI with a PLC

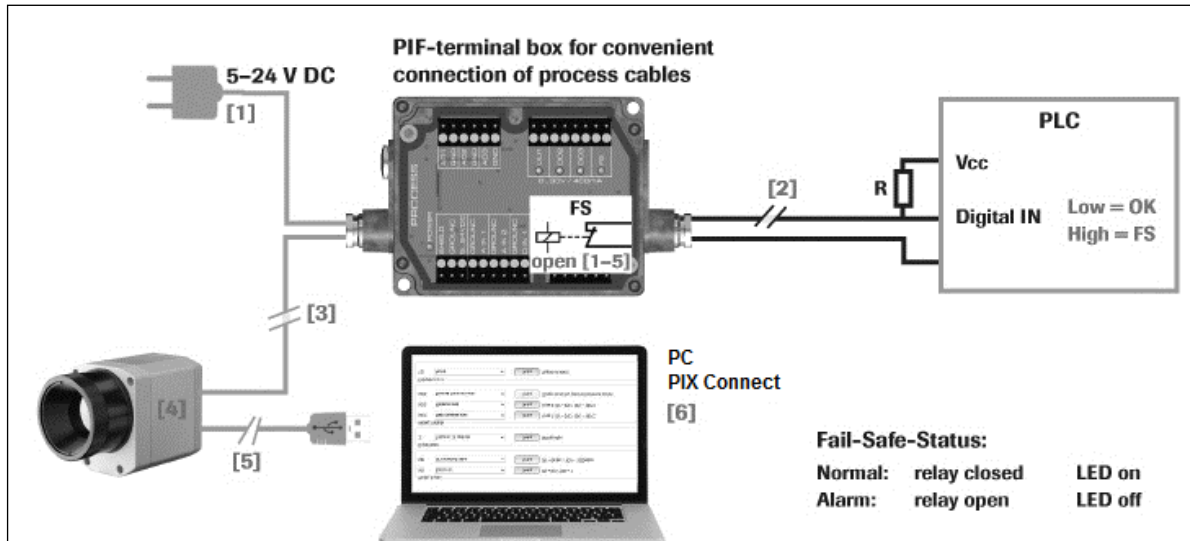

Figure 29: Fail-Safe monitoring states

Fail-Safe monitoring states

- | | | | |
|-----|--------------------------------|-----|---|
| [1] | Breakdown of PIF power supply | [4] | Malfunction of PI |
| [2] | Cable break of fail-safe cable | [5] | Breakdown of PI power supply/ Interruption of USB cable |
| [3] | Interruption of cable PI-PIF | [6] | Malfunction of PIX Connect software |

4.3 USB cable extension

The maximum USB cable length is 20 m. For greater distances between PI and computer or for stand-alone solutions the optional PI NetBox or the USB Server Gigabit is provided:

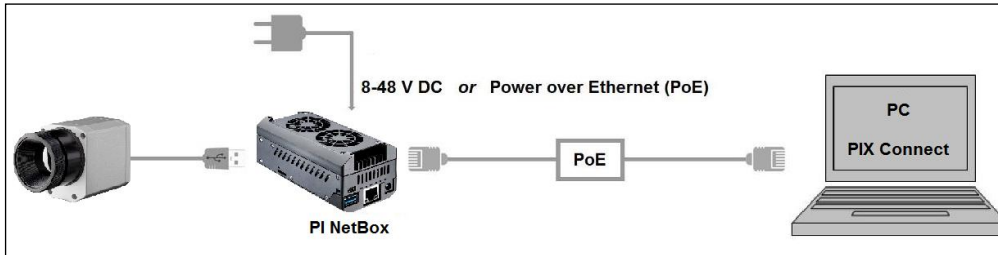

Figure 30: Ethernet direct communication with PI Netbox

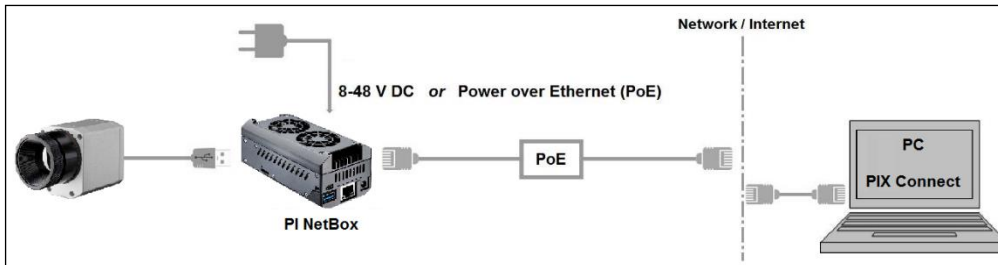

Figure 31: Ethernet network communication with PI Netbox

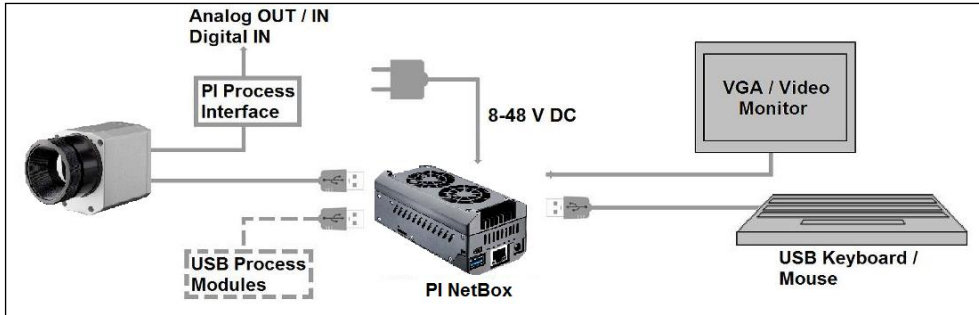

Figure 32: Stand-Alone operation with PI Netbox

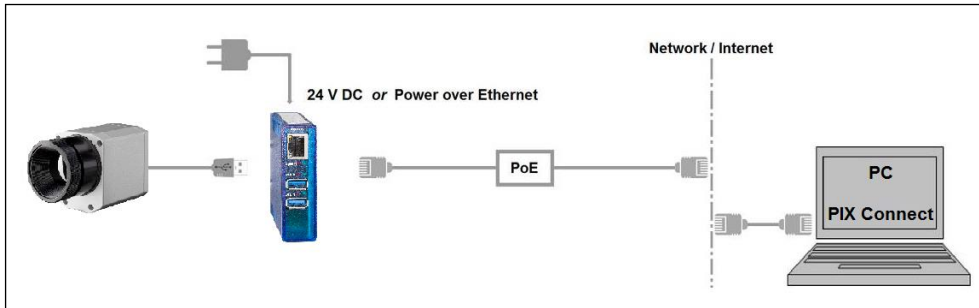

Figure 33: USB Server Gigabit

5 IRmobile App

The PI imagers have a direct connection to an Android smartphone or tablet. All you have to do is download the [IRmobile app](#) for free in the Google Play Store. This can also be done via the QR code. An IRmobile app connector is recommended for connection to the device (**Part-No.: ACPIIACM** (micro USB) or **ACPIIACC** (USB-C)).



With IRmobile you can monitor and analyze your infrared temperature measurement directly on a connected smartphone or tablet. All you need is an Optris infrared camera. This app runs on most Android (5 or higher) devices with a micro USB port or USB-C port that supports USB OTG (On The Go). The app is easy to use: After you have connected your camera to the micro USB port or USB-C port of your smartphone or tablet, the

app launches automatically. The calibration files are automatically downloaded from the internet. The device is powered by your smartphone. A hotspot indicates the hottest pixel in the image and a coldspot the coldest pixel in the image.

IRmobile app features:

- Live infrared image with automatic hot-/ and coldspot search
- Changing the color palette, scaling and temperature range
- Change of temperature unit: Celsius or Fahrenheit
- Setting of temperature range scaling (Manual, Min/Max, 3 sigma)
- Creating a snapshot
- Integrated simulator

IRmobile supported for:

- Optris IR cameras: PI and Xi series
- Optris pyrometers: Compact series, high performance series and video thermometers
- For Android 5 (or higher) devices with a micro USB port or USB C port that supports USB OTG (On The Go)



6 Software PIX Connect

Minimum system requirements:



- Windows 7, Windows 8, Windows 10
- USB interface
- Hard disc with at least 30 MByte of free space
- At least 128 MByte RAM



A detailed description is provided in the software manual on the USB stick. See also **Help** menu in the PIX Connect software (**Help** → **Documentation**).



Alternatively, the software can also be downloaded via the Optris website under the following link:
<https://www.optris.global/pix>

6.1 Installation and initial start-up



- All drivers are booted via Windows OS automatically. A driver installation is not necessary.
- By default the program starts automatically in the installed language.

1. Insert the included USB stick into the according port on your computer.
2. Please start **Setup.exe**. Follow the instructions of the wizard until the installation is finished.

The installation wizard places a launch icon on the desktop and in the start menu: **Start\Programs\Optris GmbH\PIX Connect**

3. To connect the camera to the PC, plug the USB cable to the camera first. Afterwards connect it with the PC (to disconnect the camera and the computer remove the USB cable from the computer first and then disconnect it from the camera).
4. Start the software.

At the initial start the software asks for the calibrations files which are available via internet or on the USB stick.

5. Install the calibration files at first start of the software.

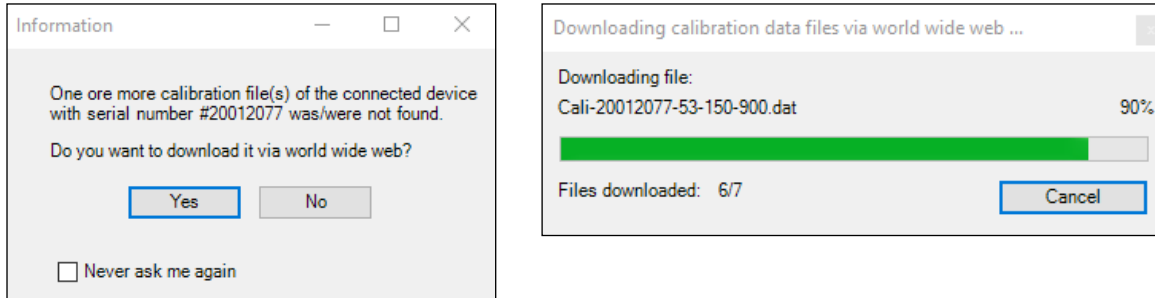

Figure 34: Calibration data transfer

After the calibration files have been installed the live image from the camera is shown inside a window on your PC screen.

6. Choose the desired language in the menu **Tools** → **Language**.
7. Adjust the focus of the image by turning the exterior lens ring at the camera.

6.2 Software window

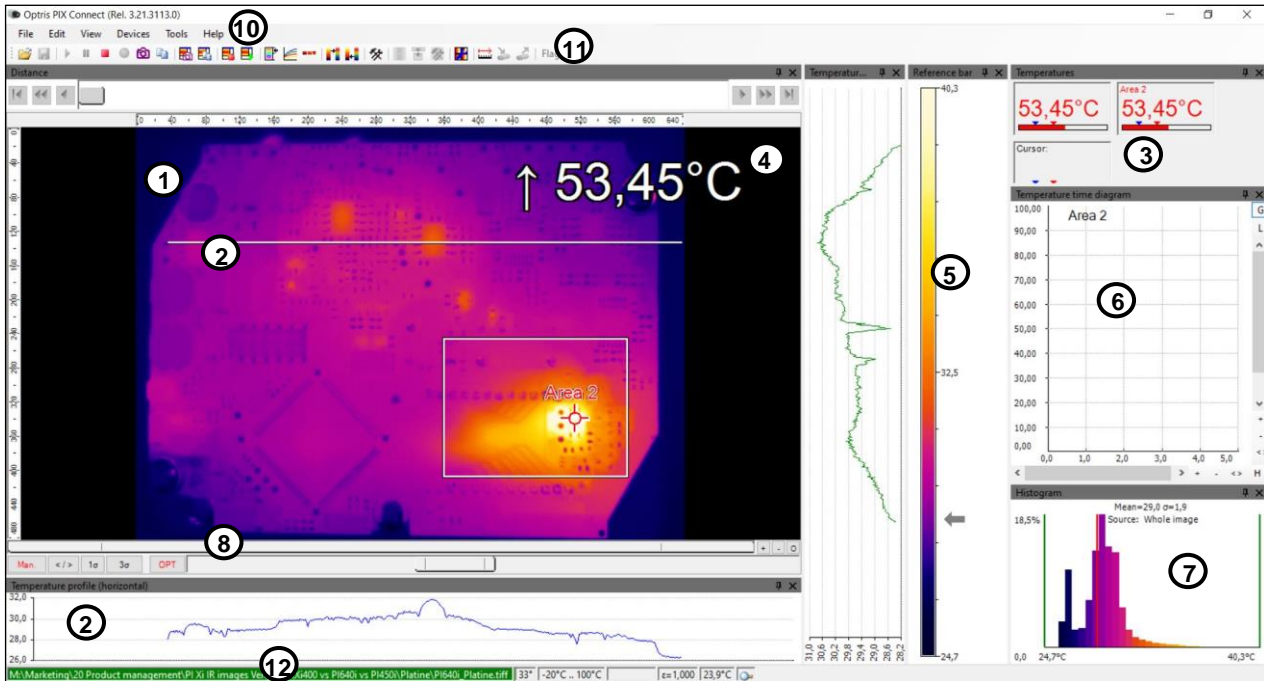

Figure 35: Software window

- 1 IR image from the camera
- 2 Temperature profile: Shows the temperatures along max. 2 lines at any size and position in the image.
- 3 Control displays: Displays all temperature values in the defined measure areas like Cold Spots, Hot Spots, temperature at cursor, internal temperature and chip temperature.

Alarm settings: Bar showing the defined temperature thresholds for low alarm value (blue arrow) and high alarm value (red arrow). The color of numbers within control displays changes to red (when temp. above the high alarm value) and to blue (when temp. below the low alarm value).
- 4 Temperature of measure area: Analyses the temperature according to the selected shape, e.g. average temperature of the rectangle. The value is shown inside the IR image and the control displays.
- 5 Reference bar: Shows the scaling of temperature within the color palette.
- 6 Temperature time diagram: Shows the temperature curves over time for selectable region of interest (ROI)
- 7 Histogram: Shows the statistic distribution of single temperature values.
- 8 Automatic / manual scaling of the palette (displayed temperature range): Man., </> (min, max), 1σ : 1 Sigma, 3σ : 3 Sigma, OPT: Palette optimization
- 10 Menu and Toolbar (Icons)
- 11 Icon enabling switching between color palettes
- 12 Status bar: Serial number, optic, temperature range, cursor position, device framerate/ display framerate, emissivity, ambient temperature, flag status

6.2.1 Basis features of the software PIX Connect

Extensive infrared camera software



- No restrictions in licensing
- Modern software with intuitive user interface
- Remote control of camera via software
- Display of multiple camera images in different windows
- Compatible with Windows 7, 8 and 10

High level of individualization for customer specific display

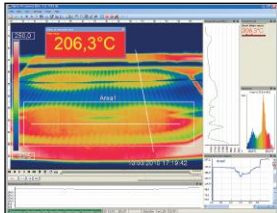

- Various language option including a translation tool
- Temperature display in °C or °F
- Different layout options for an individual setup (arrangement of windows, toolbar)
- Range of individual measurement parameter fitting for each application
- Adaption of thermal image (mirror, rotate)
- Individual start options (full screen, hidden, etc.)

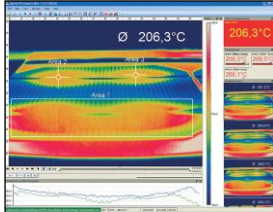

Video recording and snapshot function

- Recording of video sequences and detailed frames for further analysis or documentation
- Adjustment of recording frequency to reduce data volume
- Display of snapshot history for immediate analysis

Extensive online and offline data analysis

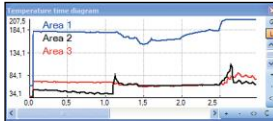

- Analysis supported by measurement fields, hot and cold spot searching, image subtraction
- Real time temperature information within main window as digital or graphic display (line profile, temperature time diagram)
- Slow motion repeat of radiometric files and analysis without camera being connected
- Editing of sequences such as cutting and saving of individual images
- Various color palettes to highlight thermal contrasts

7 Basics of Infrared Thermometry

Depending on the temperature each object emits a certain amount of infrared radiation. A change in the temperature of the object is accompanied by a change in the intensity of the radiation.

Searching for new optical material William Herschel by chance found the infrared radiation in 1800.

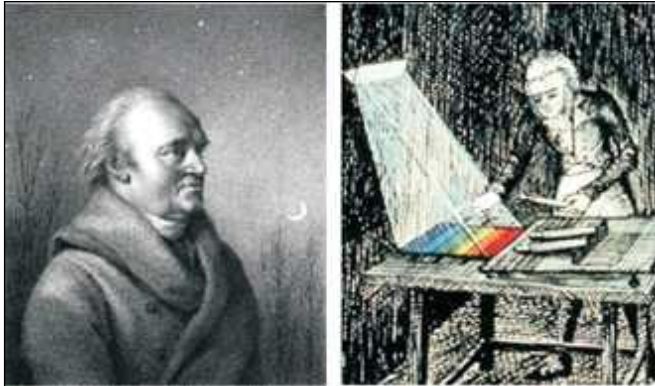

Figure 36: William Herschel (1738-1822)

He blackened the peak of a sensitive mercury thermometer. This thermometer, a glass prism that led sun rays onto a table made his measuring arrangement. With this, he tested the heating of different colors of the spectrum. Slowly moving the peak of the blackened thermometer through the colors of the spectrum, he

noticed the increasing temperature from violet to red. The temperature rose even more in the area behind the red end of the spectrum. Finally he found the maximum temperature far behind the red area.

Nowadays this area is called “infrared wavelength area”.

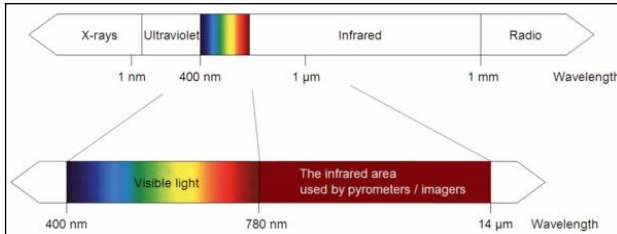

Figure 37: The electromagnetic spectrum and the area used for temperature measurement

For the measurement of “thermal radiation” infrared thermometry uses a wave-length ranging between $1\ \mu\text{m}$ and $20\ \mu\text{m}$. The intensity of the emitted radiation depends on the material. This material contingent constant is described with the help of the emissivity which is a known value for most materials (► **8 Emissivity**).

Infrared thermometers are optoelectronic sensors. They calculate the surface temperature on the basis of the emitted infrared radiation from an object. The most important feature of infrared thermometers is that they enable the user to measure objects contactless. Consequently, these products help to measure the temperature of inaccessible or moving objects without difficulties.

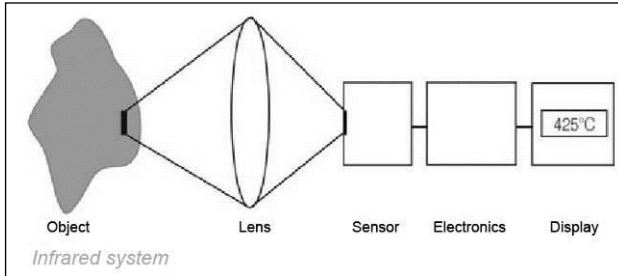

Figure 38: Main principle of non-contact thermometry

Infrared thermometers basically consist of the following components:

- Lens
- Spectral filter
- Detector
- Electronics (amplifier/ linearization/ signal processing)

The specifications of the lens decisively determine the optical path of the infrared thermometer, which is characterized by the ratio Distance to Spot size. The spectral filter selects the wavelength range, which is relevant for the temperature measurement. The detector in cooperation with the processing electronics transforms the emitted infrared radiation into electrical signals.

The advantages of non-contact thermometry are clear - it supports:

- temperature measurements of moving or overheated objects and of objects in hazardous surroundings
- very fast response and exposure times
- measurement without inter-reaction, no influence on the measuring object
- non-destructive measurement
- long lasting measurement, no mechanical wear

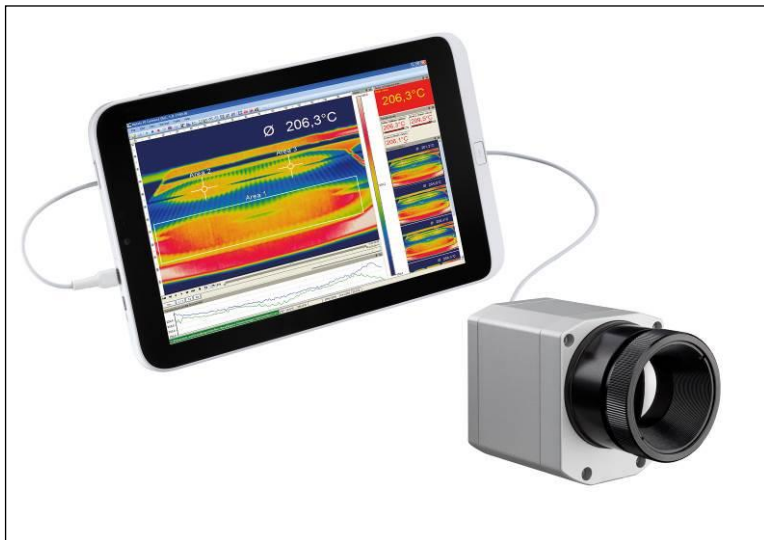
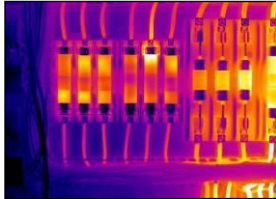
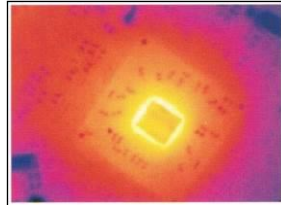

Figure 39: Non-contact thermometry

Application field:



Monitoring of electronic cabinets



R&D of electronics

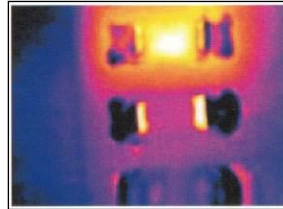

R&D of electronic parts

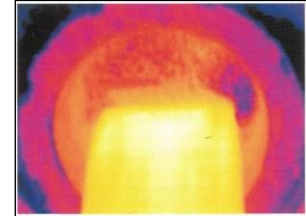

Process control extruding plastic parts

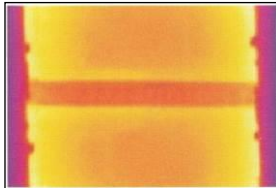

Process control manufacturing solar modules

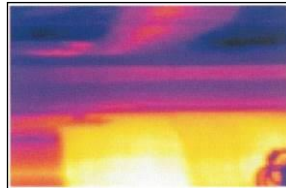

Process control at calendering

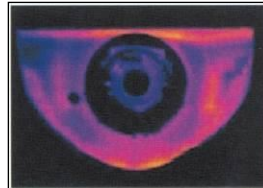

R&D of mechanical parts

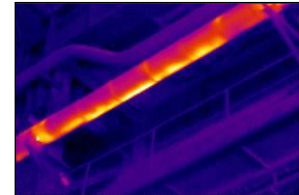

Monitoring of cables

8 Emissivity

8.1 Definition

The intensity of infrared radiation, which is emitted by each body, depends on the temperature as well as on the radiation features of the surface material of the measuring object. The emissivity (ϵ – Epsilon) is used as a material constant factor to describe the ability of the body to emit infrared energy. It can range between 0 and 100 %. A “blackbody” is the ideal radiation source with an emissivity of 1.0 whereas a mirror shows an emissivity of 0.1.

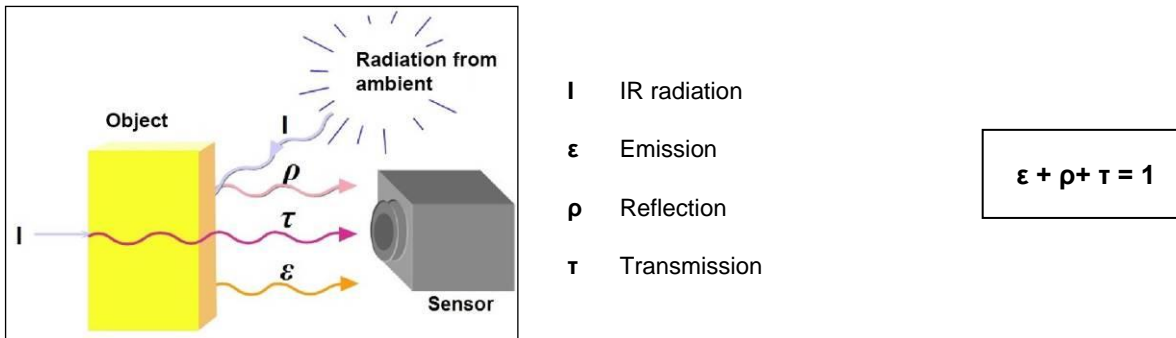

Figure 40: Composition of IR radiation

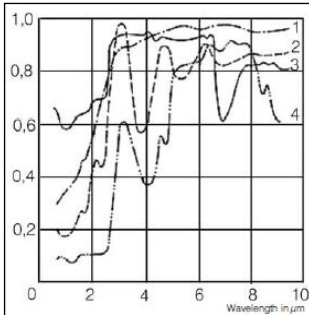

Figure 41: Spectral emissivity of several materials: **1** Enamel, **2** Plaster, **3** Concrete, **4** Chamotte

If the emissivity chosen is too high, the infrared thermometer may display a temperature value which is much lower than the real temperature – assuming the measuring object is warmer than its surroundings. A low emissivity (reflective surfaces) carries the risk of inaccurate measuring results by interfering infrared radiation emitted by background objects (flames, heating systems, chamottes). To minimize measuring errors in such cases, the handling should be performed very carefully and the unit should be protected against reflecting radiation sources.

8.2 Determination of unknown emissivity

- ▶ First determine the actual temperature of the measuring object with a thermocouple or contact sensor. Second, measure the temperature with the infrared thermometer and modify the emissivity until the displayed result corresponds to the actual temperature.
- ▶ If you monitor temperatures of up to 380 °C you may place a special plastic sticker (emissivity dots – **Part No.: ACLSED**) onto the measuring object, which covers it completely.

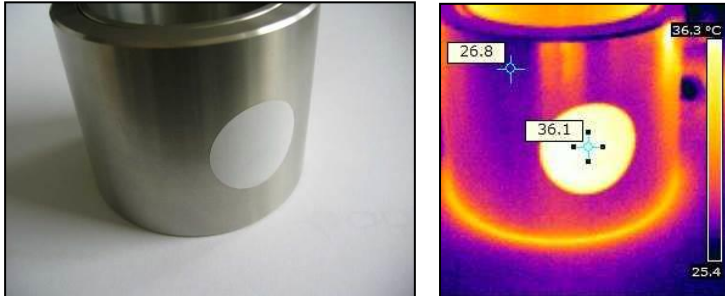

Figure 42: Plastic sticker at metal surface

Set the emissivity to 0.95 and take the temperature of the sticker. Afterwards, determine the temperature of the adjacent area on the measuring object and adjust the emissivity according to the value of the temperature of the sticker.

- ▶ Cover a part of the surface of the measuring object with a black, flat paint with an emissivity of 0.98. Adjust the emissivity of your infrared thermometer to 0.98 and take the temperature of the colored surface. Afterwards, determine the temperature of a directly adjacent area and modify the emissivity until the measured value corresponds to the temperature of the colored surface.



Figure 43: Shiny metal surface **left** and blackened metal surface **right**

CAUTION: On all three methods the object temperature must be different from ambient temperature.

8.3 Characteristic emissivity

In case none of the methods mentioned above help to determine the emissivity you may use the emissivity table ► **Appendix A** and **Appendix B**. These are average values, only. The actual emissivity of a material depends on the following factors:

- temperature
- measuring angle
- geometry of the surface
- thickness of the material
- constitution of the surface (polished, oxidized, rough, sandblast)
- spectral range of the measurement
- transmissivity (e.g. with thin films)

Fixed radiometric values

Emissivity:	1,000
Transmissivity: (IR-window compensation)	1,000
Ambient temperature:	<input type="checkbox"/> 23,0

Figure 44: Adjustment of the emissivity in the software PIX Connect (menu **Tools/ Configuration/ Device**)

Appendix A – Table of emissivity for metals

Material		typical Emissivity			
		1.0 μm	1.6 μm	5.1 μm	8-14 μm
Spectral response					
Aluminium	non oxidized	0.1-0.2	0.02-0.2	0.02-0.2	0.02-0.1
	polished	0.1-0.2	0.02-0.1	0.02-0.1	0.02-0.1
	roughened	0.2-0.8	0.2-0.6	0.1-0.4	0.1-0.3
	oxidized	0.4	0.4	0.2-0.4	0.2-0.4
Brass	polished	0.35	0.01-0.05	0.01-0.05	0.01-0.05
	roughened	0.65	0.4	0.3	0.3
	oxidized	0.6	0.6	0.5	0.5
Copper	polished	0.05	0.03	0.03	0.03
	roughened	0.05-0.2	0.05-0.2	0.05-0.15	0.05-0.1
	oxidized	0.2-0.8	0.2-0.9	0.5-0.8	0.4-0.8
Chrome		0.4	0.4	0.03-0.3	0.02-0.2
Gold		0.3	0.01-0.1	0.01-0.1	0.01-0.1
Haynes	alloy	0.5-0.9	0.6-0.9	0.3-0.8	0.3-0.8
Inconel	electro polished	0.2-0.5	0.25	0.15	0.15
	sandblast	0.3-0.4	0.3-0.6	0.3-0.6	0.3-0.6
	oxidized	0.4-0.9	0.6-0.9	0.6-0.9	0.7-0.95
Iron	non oxidized	0.35	0.1-0.3	0.05-0.25	0.05-0.2
	rusted		0.6-0.9	0.5-0.8	0.5-0.7
	oxidized	0.7-0.9	0.5-0.9	0.6-0.9	0.5-0.9
	forged, blunt	0.9	0.9	0.9	0.9
	molten	0.35	0.4-0.6		
Iron, casted	non oxidized	0.35	0.3	0.25	0.2
	oxidized	0.9	0.7-0.9	0.65-0.95	0.6-0.95

Material		typical Emissivity			
		1.0 μm	1.6 μm	5.1 μm	8-14 μm
Spectral response					
Lead	polished	0.35	0.05-0.2	0.05-0.2	0.05-0.1
	roughened	0.65	0.6	0.4	0.4
	oxidized		0.3-0.7	0.2-0.7	0.2-0.6
Magnesium		0.3-0.8	0.05-0.3	0.03-0.15	0.02-0.1
Mercury			0.05-0.15	0.05-0.15	0.05-0.15
Molybdenum	non oxidized	0.25-0.35	0.1-0.3	0.1-0.15	0.1
	oxidized	0.5-0.9	0.4-0.9	0.3-0.7	0.2-0.6
Monel (Ni-Cu)		0.3	0.2-0.6	0.1-0.5	0.1-0.14
Nickel	electrolytic	0.2-0.4	0.1-0.3	0.1-0.15	0.05-0.15
	oxidized	0.8-0.9	0.4-0.7	0.3-0.6	0.2-0.5
Platinum	black		0.95	0.9	0.9
Silver		0.04	0.02	0.02	0.02
Steel	polished plate	0.35	0.25	0.1	0.1
	rustless	0.35	0.2-0.9	0.15-0.8	0.1-0.8
	heavy plate			0.5-0.7	0.4-0.6
	cold-rolled	0.8-0.9	0.8-0.9	0.8-0.9	0.7-0.9
	oxidized	0.8-0.9	0.8-0.9	0.7-0.9	0.7-0.9
Tin	non oxidized	0.25	0.1-0.3	0.05	0.05
Titanium	polished	0.5-0.75	0.3-0.5	0.1-0.3	0.05-0.2
	oxidized		0.6-0.8	0.5-0.7	0.5-0.6
Wolfram	polished	0.35-0.4	0.1-0.3	0.05-0.25	0.03-0.1
Zinc	polished	0.5	0.05	0.03	0.02
	oxidized	0.6	0.15	0.1	0.1

Appendix B – Table of emissivity for non-metals

Material		typical Emissivity			
		1.0 μm	2.2 μm	5.1 μm	8-14 μm
Spectral response					
Asbestos		0.9	0.8	0.9	0.95
Asphalt				0.95	0.95
Basalt				0.7	0.7
Carbon	non oxidized		0.8-0.9	0.8-0.9	0.8-0.9
	graphite		0.8-0.9	0.7-0.9	0.7-0.8
Carborundum			0.95	0.9	0.9
Ceramic		0.4	0.8-0.95	0.8-0.95	0.95
Concrete		0.65	0.9	0.9	0.95
Glass	plate		0.2	0.98	0.85
	melt		0.4-0.9	0.9	
Grit				0.95	0.95
Gypsum				0.4-0.97	0.8-0.95
Ice					0.98
Limestone				0.4-0.98	0.98
Paint	non alkaline				0.9-0.95
Paper	any color			0.95	0.95
Plastic >50 μm	non transparent			0.95	0.95
Rubber				0.9	0.95
Sand				0.9	0.9
Snow					0.9
Soil					0.9-0.98
Textiles				0.95	0.95
Water					0.93
Wood	natural			0.9-0.95	0.9-0.95

Appendix C – Quick start for serial communication

Introduction

One special feature of the PIX Connect software contains the possibility to communicate via a serial COM-Port interface. This can be a physical COM-Port or a virtual COM-Port (VCP). It must be available on the computer where the PIX Connect software is installed.

Setup of the interface

1. Open the **Configurations** dialog and enter the tab “**External Communication**” to enable the software for the serial communication.

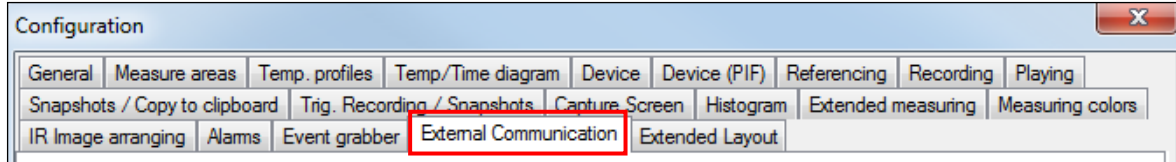

2. Select the mode “**COM-Port**” and choose the appropriate port.

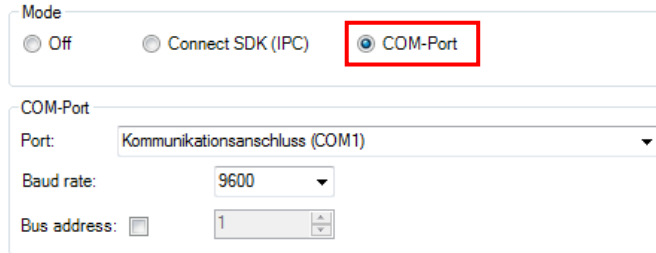

Mode

Off Connect SDK (IPC) COM-Port

COM-Port

Port:

Baud rate:

Bus address:

3. Select the baud rate that matches the baud rate of the other communication device. The other interface parameters are 8 data bits, no parity and one stop bit (8N1).

These parameters are used in many other communication devices too. The other station must support 8 bit data.

4. Connect the computer with the communication device. If this is a computer too, use a null modem cable.

Command list



The command list is provided on the USB stick and in the PIX Connect software (`help` → `SDK`). Every command must expire with CR/LF (0x0D, 0x0A).

Appendix D – Interprocess Communication (IPC)



The description of the initialization procedure as well as the necessary command list is provided on the USB stick and in the PIX Connect software (**Help** → **SDK**).

2 SDK packages are available (included on USB stick):

1. **Connect SDK:** requires the PIX Connect software
2. **Direct SDK:** no PIX Connect software required, supports Linux and Windows

The communication to the process imager device is handled by the PIX Connect software (**Imager.exe**) only. A dynamic link library (**ImagerIPC2.dll**) provides the interprocess communication (IPC) for other attached processes. The DLL can be dynamically linked into the secondary application. Or it can be done static by a lib file too. Both **Imager.exe** and **ImagerIPC2.dll** are designed for Windows 7/ 8/ 10 only. The application must support call-back functions and polling mode.

The **ImagerIPC2.dll** will export a bunch of functions that are responsible for initiating the communication, retrieving data and setting some control parameters.

The main difference to the former Version 1 (**ImagerIPC.dll**) is the support of more than one Optris PI via multiple instances of Optris PIX Connect.

Appendix E – PIX Connect Resource Translator



A detailed tutorial is provided on the USB stick.

PIX Connect is a **.Net Application**. Therefore it is ready for localization. Localization as a Microsoft idiom means a complete adaption of resources to a given culture. Learn more about the internationalization topics consult Microsoft's developer documentation on

<http://msdn.microsoft.com/en-us/goglobal/bb688096.aspx>.

If desired the localization process can be illustrated in detail. Also the resizing of buttons or other visible resources and the support of right-to-left-languages are supported. Experts who have the appropriate tools should handle it. Nevertheless we have developed the small tool "**Resource Translator**" to make the translation of the resources of the PIX Connect application possible for everybody.

This tool helps to translate any visible text within the PIX Connect application.

Appendix F – Wiring diagrams PIF

Analog Output:

The maximum load impedance is 500 Ohm.

The analog output can be used as a digital output too. The current value for “no alarm” and “alarm on” is set within the software.

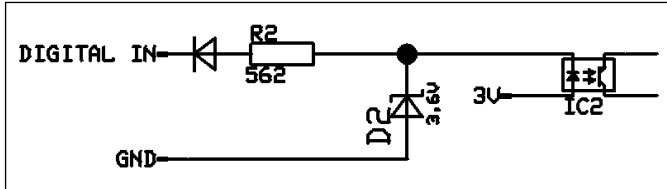
Digital Input:**Figure 45:** Digital input

The digital input can be activated with a button to the PI GND-Pin or with a low level CMOS/TTL signal: Low level 0...0.6 V; High level 2...24 V

Example Button:

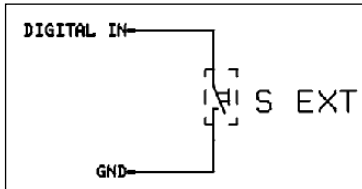
**Figure 46:** Button

Analog input (usable voltage range: 0 ... 10 V):

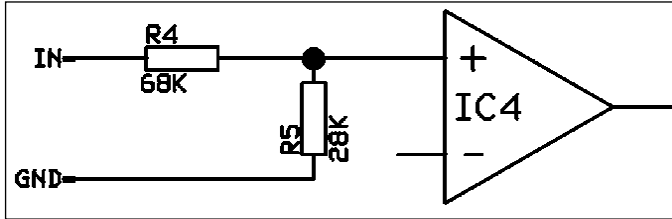

Figure 47: Analog input

Relay output at industrial PIF [Part No.: ACPIPIFMACBxx]

The analog output must be set to “Alarm”. The range for AO1-AO3 can be set in the software (no alarm: 0-4 mA/ alarm: 10-20 mA).

REL1-3 (DO1-DO3): $U_{\max} = 30 \text{ VDC}$

$I_{\max} = 400 \text{ mA}$

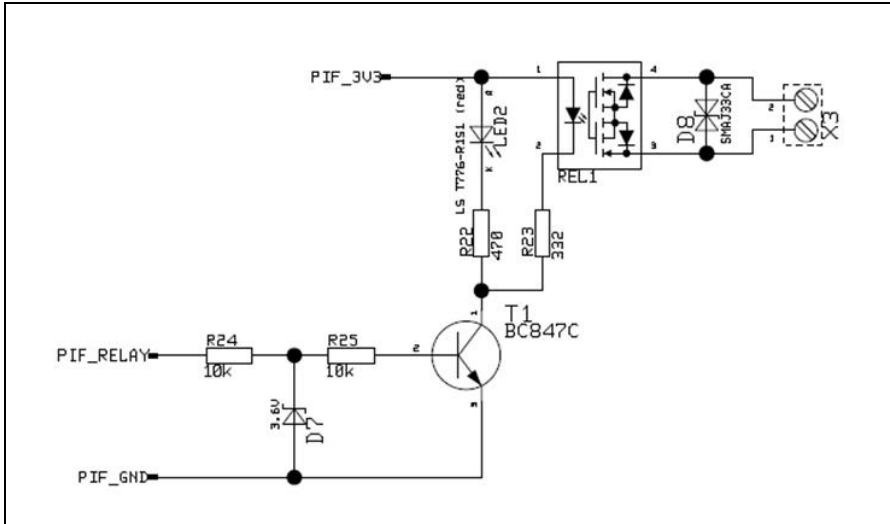

Figure 48: Relay output at industrial PIF

Appendix G – Declaration of Conformity

EG-Konformitätserklärung EU Declaration of Conformity



Wir / We

Optris GmbH
Ferdinand Buisson Str. 14
D-13127 Berlin

erklären in alleiniger Verantwortung, dass
declare on our own responsibility that

die Produktserie optris PI
the product group optris PI

den Anforderungen der EMV-Richtlinie 2014/30/EU und der Niederspannungsrichtlinie 2014/35/EU entspricht.

meets the provisions of the EMC Directive 2014/30/EU and the Low Voltage Directive 2014/35/EU.

Angewandte harmonisierte Normen:
Applied harmonized standards:

EMV Anforderungen / EMC General Requirements:
EN 61326-1:2021 (Grundlegende Prüfanforderungen / Basic requirements)
EN 61326-2-3:2021

Gerätesicherheit von Messgeräten / Safety of measurement devices:

EN 61010-1:2010/A1:2019/AC:2019-04
EN 60825-1:2014 + AC:2017 + A11:2021 + A11:2021/AC:2022 (Lasersicherheit / Laser safety)

Beschränkung gefährlicher Stoffe / Restriction of hazardous substances:

EN IEC 63000:2018

Dieses Produkt erfüllt die Vorschriften der Richtlinie 2015/863/EU (RoHS) des Europäischen Parlaments und des Rates vom 4. Juni 2015 zur Beschränkung der Verwendung bestimmter gefährlicher Stoffe in Elektro- und Elektronikgeräten.
This product is in conformity with Directive 2015/863/EU (RoHS) of the European Parliament and of the Council of 4 June 2015 on the restriction of the use of certain hazardous substances in electrical and electronic equipment.

Berlin, 13.06.2023
Ort, Datum / place, date



Dr. Ulrich Kienitz
Geschäftsführer / General Manager

optris PI-MA-E2023-08-A