

IR camera for the detection  
of slightest temperature  
differences

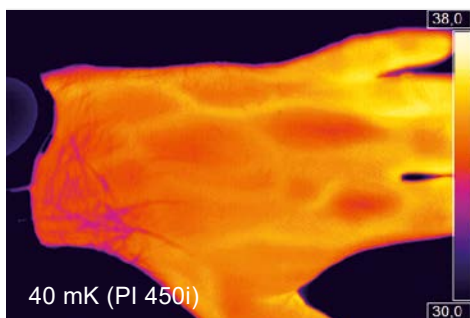

Features:

- Smallest camera in its class (46 x 56 x 68 – 77 mm)
- Interchangeable lenses and industrial accessories
- Superb thermal sensitivity of 40 mK
- Licence-free analysis software and full SDK included

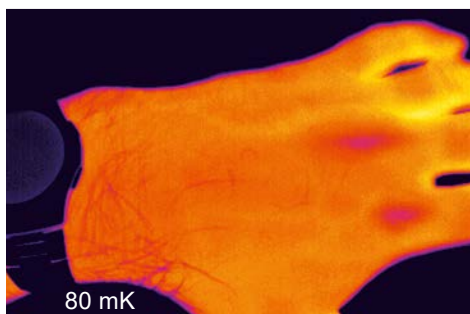
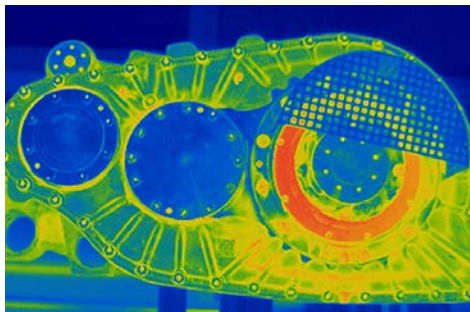

For further information as well as  
the product configurator, please visit

[www.optris.global/thermal-imager-optris-pi-400i-pi-450i](http://www.optris.global/thermal-imager-optris-pi-400i-pi-450i)

Technical specifications

Optical resolution	382 x 288 pixels
Detector	FPA, uncooled (17 µm x 17 µm)
Spectral range	8 – 14 µm
Temperature ranges	-20 ... 100 °C, 0 ... 250 °C, (20) 150 ... 900 °C <sup>1)</sup> , optional temperature range: 200 ... 1500 °C
Frame rate	80 Hz / switchable to 27 Hz
Optics (FOV)	18° x 14° / f = 20 mm or 29° x 22° / f = 12,7 mm or 53° x 38° / f = 7,7 mm or 80° x 54° / f = 5,7 mm
Thermal sensitivity (NETD)	40 mK with 29° x 22° FOV / F = 0.9 40 mK with 53° x 38° FOV / F = 0.9 40 mK with 80° x 54° FOV / F = 0.9 0.06 K with 18° x 14° FOV / F = 1.1
System accuracy	±2 °C or ±2 %, whichever is greater
PC interfaces	USB 2.0 / optional USB to GigE (PoE) interface
Standard process interface (PIF)	0 – 10 V input, digital input (max. 24 V), 0 – 10 V output
Industrial process interface (PIF) (optional)	2x 0 – 10 V input, digital input (max. 24 V), 3x 0/4 – 20 mA output, 3x relay (0 – 30 V/ 400 mA), fail-safe relay
Cable length (USB)	1 m (standard), 5 m, 10 m, 20 m 5 m and 10 m available as high temperature USB cable (180 or 250 °C)
Ambient temperature	0 ... 70 °C
Storage temperature	-40 ... 85 °C
Relative humidity	20 – 80 %, non condensing
Enclosure (size / protection)	46 x 56 x 68–77 mm (depending on lens + focus position) / IP 67 (NEMA 4)
Weight	237 - 251 g (depending on lens)
Shock / Vibration <sup>2)</sup>	IEC 60068-2-27 (25G and 50G) / IEC 60068-2-6 (sinus shaped), IEC 60068-2-64 (broadband noise)
Tripod mount	¼ – 20 UNC
Power supply	via USB
Scope of supply (standard)	<ul style="list-style-type: none"> <li>• USB camera, incl. lens</li> <li>• USB cable (1 m)</li> <li>• Table tripod</li> <li>• PIF cable, incl. terminal block (1 m)</li> <li>• Software package optris PIX Connect</li> <li>• Test certificate</li> <li>• Rugged outdoor transport case (IP67)</li> </ul>

<sup>1)</sup> Accuracy for the (20°C) 150 °C ... 900 °C range effective starting at 150 °C

<sup>2)</sup> For further information see operator's manual.

# optris PI 450i

## Dimensions

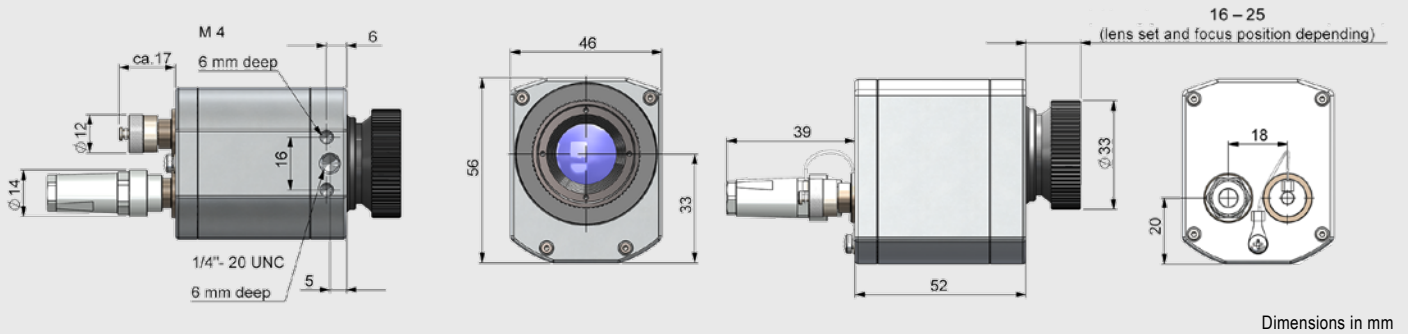

## Process integration

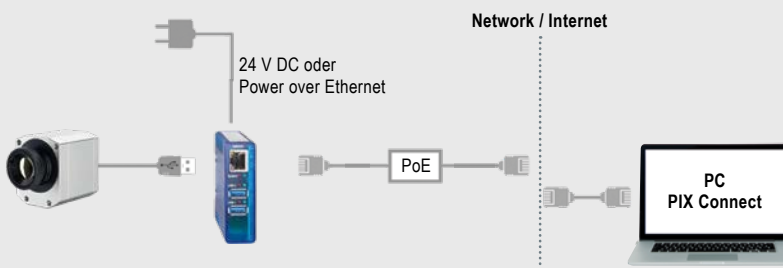

### optris USB-Server Gigabit 2.0

- Network connection via Gigabit Ethernet
- Full TCP/IP support incl. routing and DNS
- Two independent USB ports
- Power via PoE or external voltage supply at 24 – 48 V DC
- Galvanic isolation 500 V<sub>RMS</sub>
- Remotely configurable via web based management

For further information please visit [www.optris.global/usb-server-gigabit](http://www.optris.global/usb-server-gigabit)

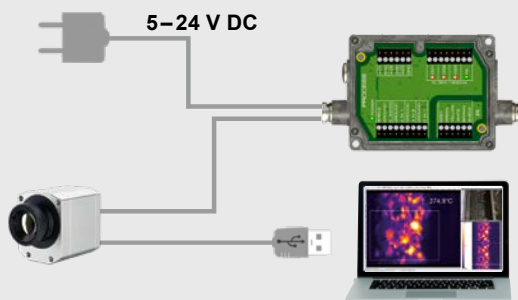

### optris Industrial Process Interface

- Use of camera for process monitoring in industrial environments
- Continuous fail safe monitoring of imager, software and cable connections
- 3 analog/ alarm outputs, 2 analog inputs, 1 digital input, 3 alarm relays, 1 fail-safe relay

For further information please visit [www.optris.global/neu-industrial-process-interface](http://www.optris.global/neu-industrial-process-interface)

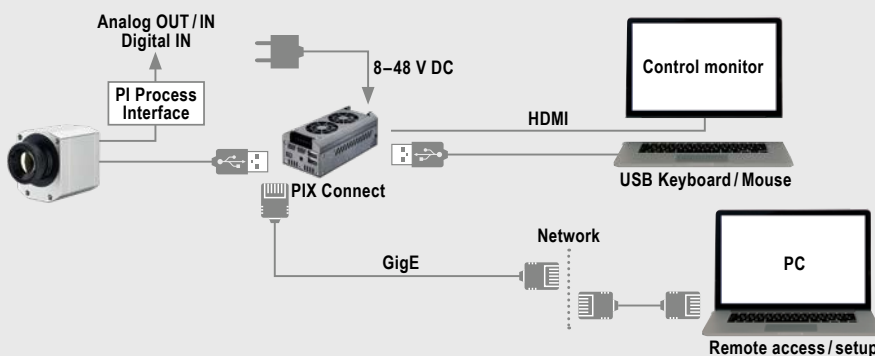

### optris PI NetBox

- Miniature PC as add-on to the PI series for stand-alone system
- Integrated hardware and software watchdog
- Connections: 2x USB 2.0, 1x USB 3.0, 1x Mini-USB 2.0, Micro-HDMI, Ethernet (Gigabit Ethernet), micro SDHC / SDXC card

For further information please visit [www.optris.global/pi-netbox](http://www.optris.global/pi-netbox)